

EAT•N

Cutler-Hammer

**MVX9000 AF Drives
User Manual**



Safety Instructions

Safety Messages

For the best results with the MVX9000 inverter, carefully read this manual and all of the warning labels attached to the inverter before installing and operating it, and follow the instructions exactly. Keep this manual handy for quick reference.

Definitions and Symbols

A safety instruction (message) includes a hazard alert symbol and a signal word, WARNING or CAUTION. Each signal word has the following meaning:



HIGH VOLTAGE: This symbol indicates high voltage. It calls your attention to items or operations that could be dangerous to you and other persons operating this equipment. Read the message and follow the instructions carefully.



This symbol is the “Safety Alert Symbol.” It occurs with either of two signal words: CAUTION or WARNING, as described below.



WARNING: Indicates a potentially hazardous situation which, if not avoided, can result in serious injury or death.



CAUTION: Indicates a potentially hazardous situation which, if not avoided, can result in minor to moderate injury, or serious damage to the product. The situation described in the CAUTION may, if not avoided, lead to serious results. Important safety measures are described in CAUTION (as well as WARNING).

Hazardous High Voltage



HIGH VOLTAGE: Motor control equipment and electronic controllers are connected to hazardous line voltages. When servicing drives and electronic controllers, there may be exposed components with housings or protrusions at or above line potential. Extreme care should be taken to protect against shock.

Stand on an insulating pad and make it a habit to use only one hand when checking components. Always work with another person in case an emergency occurs. Disconnect power before checking controllers or performing maintenance. Be sure equipment is properly grounded. Wear safety glasses whenever working on electronic controllers or rotating machinery.

Warnings, Notes and Cautions



Always read this manual thoroughly before using MVX9000 AC Motor Drives.



HIGH VOLTAGE!

Be sure to ground the unit. Otherwise, there is danger of electric shock and/or fire.



HIGH VOLTAGE!

Wiring work shall be carried out only by qualified personnel. Otherwise, there is a danger of electric shock or fire.



WARNING!

AC input power must be disconnected before any maintenance. Do not connect or disconnect wires and connectors while power is applied to the circuit. Maintenance must be performed by qualified technicians.



WARNING!

A hazardous voltage charge may still remain in the DC-link capacitor even if the power has been turned off. To avoid personal injury, do not remove the cover of the AC drive until all "DISPLAY LED" lights on the digital keypad are off. Please note that there are live components exposed within the AC drives. Do not touch these live parts.



WARNING!

The AC drive may be destroyed beyond repair if incorrect cables are connected to the input/output terminals. Never connect the AC drive output terminals T1, T2, and T3 directly to the AC main circuit power supply.



WARNING! Hazardous Voltage

Before opening the AC drive covers:

- **Disconnect all power to the AC drive.**

Wait five minutes for DC bus capacitors discharge.

Any Electrical or mechanical modification to this equipment without prior written consent of Eaton Cutler-Hammer will void all warranties and may result in a safety hazard in addition to voiding the UL listing.



WARNING!

Wait at least 2 minutes after all display lamps have gone out, and then confirm that the capacitors have fully discharged by measuring the voltage between B1 and Ground using a multi meter set to measure DC.



WARNING!

Opening the Drive voids the warranty!



WARNING!

Make sure that all screws are tightened to the proper torque rating shown in Table 3-2.



WARNING!

This equipment should be installed, adjusted, and serviced by qualified electrical maintenance personnel familiar with the construction and operation of the equipment and the hazards involved. Failure to observe this precaution could result in bodily injury.



WARNING!

“Use 75°C Cu wire only” or equivalent.



WARNING!

“Suitable for use on a circuit capable of delivering not more than 5,000 rms symmetrical amperes, 240 V maximum.”



WARNING!

“Suitable for use on a circuit capable of delivering not more than 5,000 rms symmetrical amperes, 480 V maximum.”



WARNING!

Disconnect AC power before proceeding!



CAUTION!

There are highly sensitive MOS components on the printed circuit boards. These components are especially sensitive to static electricity. To avoid damage to these components, do not touch these components or the circuit boards with metal objects or your bare hands.



CAUTION!

Ground the MVX9000 using the ground terminal. The grounding method must comply with the laws of the country where the AC drive is to be installed. Refer to the Basic Wiring Diagram in Chapter 3.



CAUTION!

Do not connect the AC power to the T1, T2, T3 terminals, it will damage the AC drive.



CAUTION!

Be sure to install the unit on flame-resistant material such as a steel plate. Otherwise, there is the danger of fire.



CAUTION!

Be sure to install the unit on a perpendicular wall which is not subject to vibration. Otherwise, it may fall and cause injury to personnel.



CAUTION!

Be sure not to let the foreign matter enter vent openings in the inverter housing, such as wire clippings, spatter from welding, metal shavings, dust, etc. Otherwise, there is the danger of fire.



CAUTION!

Be sure not to install or operate an inverter which is damaged or has missing parts. Otherwise, it may cause injury to personnel.



CAUTION!

Be sure to install the inverter in a well-ventilated room which does not have direct exposure to sunlight, a tendency for high temperature, high humidity or dew condensation, high levels of dust, corrosive gas, explosive gas, inflammable gas, grinding-fluid mist, salt damage, etc. Otherwise, there is the danger of fire.



CAUTION!

Be sure that the input voltage matches the inverter specifications:

- Single/Three phase 200 to 240 V 50/60 Hz (up to 2.2kW)
 - Three phase 200 to 230 V 50/60 Hz (above 2.2kW)
 - Three phase 380 to 460 V 50/60 Hz
-



CAUTION!

Be sure not to connect an AC power supply to the output terminals. Otherwise, there is the danger of injury and/or fire.

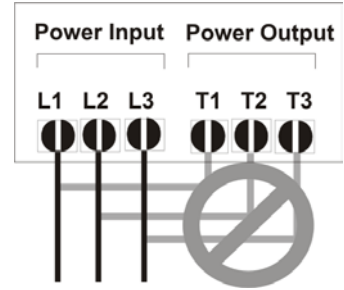

Note:

L1, L2, L3: Three-phase 200 to 230V 50/60 Hz
 Three-phase 380 to 460V 50/60 Hz

Any two inputs: Single-phase 200 to 240V 50/60 Hz



CAUTION!

The operation of the inverter can be easily changed from low speed to high speed. Be sure to check the capability and limitations of the motor and machine before operating the inverter. Otherwise, there is the danger of injury.



CAUTION!

If you operate a motor at a frequency higher than the inverter standard default setting (50Hz/60Hz), be sure to check the motor and machine specifications with the respective manufacturer. Only operate the motor at elevated frequencies after getting their approval. Otherwise, there is the danger of equipment damage.

This page intentionally left blank.

Table of Contents

Safety Instructions	i
Safety Messages	i
Definitions and Symbols	i
Hazardous High Voltage.....	i
Warnings, Notes and Cautions.....	ii
Table of Contents	vii
Chapter 1 – Introduction	1-1
Chapter 2 – Overview of the MVX9000 Drive	2-1
Receiving and Inspection	2-1
Digital Keypad Operation	2-3
Chapter 3 – Storage and Installation	3-1
Storage	3-1
Environment	3-1
Mounting Area	3-2
Wiring.....	3-3
Applicable Codes.....	3-3
Basic Wiring Diagram	3-4
External Wiring.....	3-5
Control Terminal Wiring (Factory Settings).....	3-6
Main Circuit Wiring	3-7
Motor Operation Precautions	3-9
Chapter 4 – Start-up Procedures	4-1
Step-by-Step Installation	4-1
Mounting Location.....	4-1
Inverter Mounting	4-3
Wiring Preparation	4-4
Wiring the Inverter to Incoming Power.....	4-8
Wiring the Motor to the Inverter Output	4-8
Powerup Test.....	4-9
Chapter 5 – Descriptions of Parameter Settings.....	5-1
Parameter Groups	5-3

Group 20 — Basic Grouping (Quick Start)	5-4
Group 30 — Inputs.....	5-6
Group 40 — Outputs.....	5-24
Group 50 — AC Drive Control	5-28
Group 60 — Motor Control.....	5-45
Group 70 — Protective Functions.....	5-49
Group 80 — Display.....	5-54
Group 90 — Communications.....	5-58
Chapter 6 – Maintenance and Inspection	6-1
Periodic Inspection.....	6-1
Periodic Maintenance	6-1
Chapter 7 – Troubleshooting and Fault Information	7-1
Common Problems and Solutions	7-1
Warning codes	7-4
MVX9000 Parameter Listing	B-1
20 — BASIC GROUPING (Quick Start).....	B-1
30 — INPUTS.....	B-2
40 — OUTPUTS.....	B-4
50 — DRIVE CONTROL	B-5
60 — MOTOR CONTROL.....	B-8
70 — PROTECTIVE.....	B-9
80 — KEYPAD/DISPLAY	B-10
90 — COMMUNICATION PARAMETERS.....	B-12
Fuse Specification Chart.....	C-1
Wiring Table	C-2
All Braking Resistors & Braking Units Used in AC Drives	C-3
EMI Filter Cross Reference.....	C-4
EMI Filters	C-5
Din Rail Adapter (P/N: MVXDR)	C-9
Remote Kit (P/N: MVXRM)	C-10
Extension Input/Output (P/N: MVXEIO).....	C-10

Chapter 1 – Introduction

This chapter describes the purpose and contents of this manual and the intended audience. This chapter also explains conventions used in this manual and lists related publications.

How to Use This Manual

The purpose of this manual is to provide you with information necessary to install, set parameters, troubleshoot, and maintain the AC motor drives. To guarantee safe operation of the equipment, read the safety guidelines at the beginning of this manual before connecting power to the AC motor drives. Keep this operating manual handy and distribute to all users for reference.

Chapter 1 – Introduction is the chapter you are reading now.

Chapter 2 – Overview of the MVX9000 Drive describes receiving and inspection procedures and provides an introduction to digital keypad operation.

Chapter 3 – Storage and Installation describes planning for drive installation and drive mounting. This chapter also includes requirements and connections for wiring.

Chapter 4 – Start-up Procedures provides a detailed explanation of digital keypad operation.

Chapter 5 – Descriptions of Parameter Setting provides detailed explanations for all parameter settings.

Chapter 6 – Maintenance and Inspection describes maintenance procedures.

Chapter 7 – Troubleshooting and Fault Information lists the fault displays, descriptions, and corrective actions.

Appendix A – Technical Data lists standard specifications.

Appendix B – Summary of Parameter Settings provides brief descriptions of all parameters and their settings.

Appendix C – Accessories provides information about circuit breakers, fuses, braking resistors, and other accessories for the Cutler-Hammer MVX9000 Drives.

Appendix D – Dimensions displays keypad and drive dimensions.

Appendix E – is a Declaration of Conformity.

Intended Audience

The audience for this manual has:

- Knowledge of standard electrical wiring practices, electronic components, and electrical schematic symbols.

The audience for this manual will install, start-up, and service the Cutler-Hammer MVX9000 Drives.

Conventions Used in this Manual

Listed below are terms and language conventions used in this manual. These terms and conventions are defined here to help you understand their meanings and applications throughout this manual.

Digital Keypad Display

The Digital Keypad display is an LED readout of drive parameter selections and drive operation status. Letters or numbers appear in the display according to which keys you press.

Digital Keypad Keys

Digital Keypad keys are flat, labeled, push-button-type devices that allow you to select drive parameters, and monitor drive operation.

Parameter

A parameter is selected through the Digital Keypad. Parameters in this manual are expressed as Parameter Group Number, a decimal (.), and a Parameter number.

Press

Press a key on the Digital Keypad Control Panel to select a parameter. Refer to *Chapter 2 – Overview of the MVX9000 Drive, Digital Keypad*.

Warranty and Liability Information

CUTLER-HAMMER warrants the product delivered in the CUTLER-HAMMER shipping package to be free from defects in material and workmanship, under normal use and service, for twenty four (24) months from date of manufacturing. Products that fail during this period will be repaired or replaced at CUTLER-HAMMER's discretion, with the same or a functionally equivalent product, provided the original purchaser (A) returns the failed product, and (B) provides proof of original date of purchase. This warranty does not apply, in the judgment of CUTLER-HAMMER, to damage caused during shipment, handling, storage, or accidental misuse. The original purchaser of the product must obtain a Return Material Authorization (RMA) number from CUTLER-HAMMER prior to returning any defective product. (When purchased through an Authorized Distributor, the Distributor should supply an RMA number to their customer.)

The maximum liability of this warranty is limited to the purchase price of the product. In no event, regardless of cause, shall CUTLER-HAMMER be liable (a) for penalties or penalty clauses of any description, or (b) for certification not otherwise specifically provided herein and/or indemnification of purchaser or others for costs, damages or expenses, each arising out of or related to the product or services of any order or (c) for any damages resulting from loss of profits, use of products or for any incidental indirect or consequential damages, even if advised of the possibility of such damages.

Related Publications

Brochure (Publication Number: BR04002001E)

Technical Document (Publication Number: TD04002001E)

Manual (Publication Number: 5011614100)

Contact Name, Number:

Eaton Corporation

Cutler-Hammer Business Unit

1000 Cherrington Parkway

Moon Township, PA 15108-4312

Tel: 1-800-525-2000

www.cutler-hammer.eaton.com

This page intentionally left blank.

Chapter 2 – Overview of the MVX9000 Drive

Receiving and Inspection

This MVX9000 AC drive has gone through quality control tests at the factory before shipment. After receiving the AC motor drive, please check for the following:

- Check to make sure that the package includes an AC drive and User Manual.
- Inspect the unit to insure it was not damaged during shipment.
- Make sure that the part number indicated on the nameplate corresponds with the part number of your order.

Nameplate Information

Example of 0.5HP 230V AC drive

The nameplate for the Eaton Cutler-Hammer MVXF50A0-2 AC drive contains the following information:

- Logos:** Eaton and Cutler-Hammer.
- Cat. No.:** MVXF50A0-2
- Style No.:** MVXF50A0-2
- Input Spec.:** 200-240Vac, 50-60Hz, 1ph, 6.3A/3ph, 3.2A
- Output Spec.:** 0-240Vac, 3ph, 2.5A, 0.5HP
- Output frequency Rang:** 0.1-400Hz Output
- Serial Number Bar Code:** 10782116036223
- Serial Number Bar Code:** F50A02T2410002
- MADE IN:** xxxxxx
- Certifications:** UL LISTED Ind. Cont. Eq. 19XX, CE.

Catalog Number

Diagram illustrating the breakdown of the catalog number **MVX F50 A 0 - 2**:

- MVX:** Model Number
- F50:** Motor Horsepower (0.5 HP (0.4 kW))
- A:** Enclosure
- 0:** Version Type
- 2:** 2:240 VAC, 4:480 VAC

Motor Horsepower options:

F50: 0.5 HP (0.4 kW)	005: 5.0 HP (3.7 kW)
001: 1.0 HP (0.7 kW)	007: 7.5 HP (5.5 kW)
002: 2.0 HP (1.5 kW)	010: 10 HP (7.5 kW)
003: 3.0 HP (2.2 kW)	

Style Number

The style number contains the same information as the catalog number, and is used internally for ordering purposes.

External Parts and Label Locations

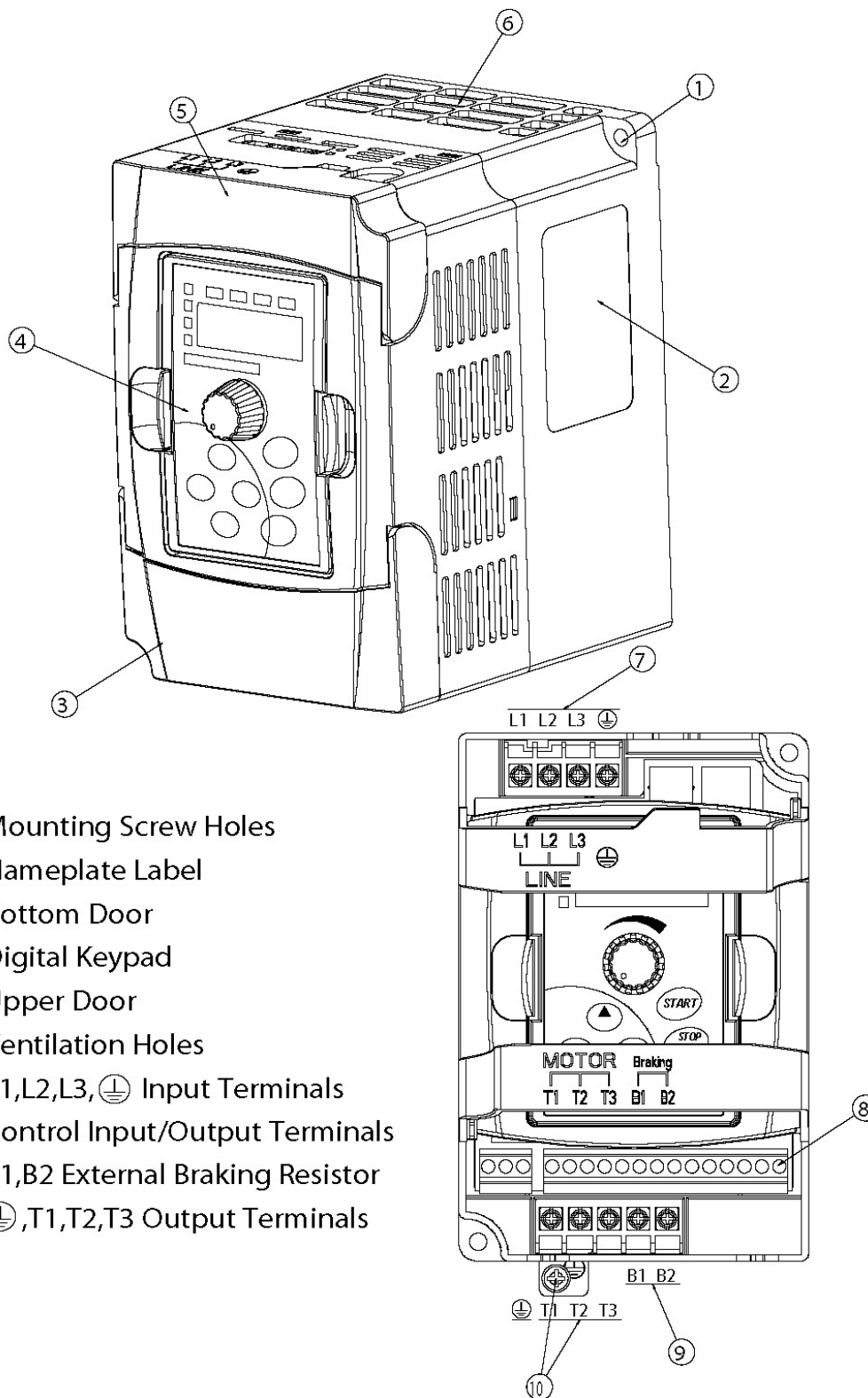

- ① :Mounting Screw Holes
- ② :Nameplate Label
- ③ :Bottom Door
- ④ :Digital Keypad
- ⑤ :Upper Door
- ⑥ :Ventilation Holes
- ⑦ :L1,L2,L3, ⊕ Input Terminals
- ⑧ :Control Input/Output Terminals
- ⑨ :B1,B2 External Braking Resistor
- ⑩ :⊕,T1,T2,T3 Output Terminals

Digital Keypad Operation

The digital keypad includes the display panel and the keypad. The display panel provides the parameter display and shows the operation status of the AC drive. The keypad provides programming and control interface.

Description of Digital Keypad

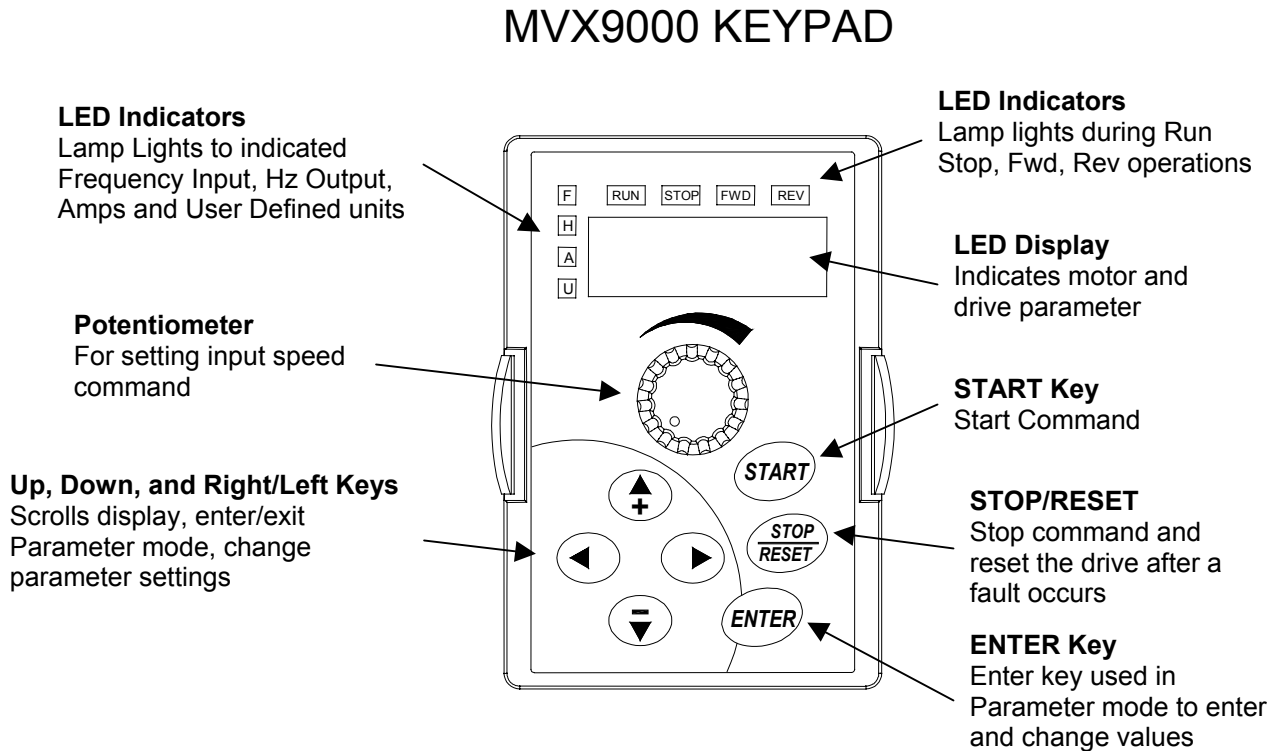

Explanation of the LED Indicators







LED Displays



- Red lamp lights during REV operation.
- Red lamp lights during FWD operation.
- Red lamp lights by pressing STOP.
- Red lamp lights by pressing RUN.



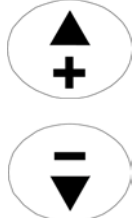









- F** — Lamp lights to indicate input frequency reference
- H** — Lamp lights to indicate output Hz
- A** — Lamp lights to indicate output amps
- U** — Lamp lights to indicate user defined units

Table 2-1 Keypad Operators

	<p style="text-align: center;">Start</p> <p>This button operates as Start button for normal operation.</p> <ul style="list-style-type: none"> Motor START from the panel; active control place has to be selected at 'Panel'
	<p style="text-align: center;">Enter</p> <p>This button in the parameter edit mode is used to enter the programming mode and enter the parameter selection.</p> <ul style="list-style-type: none"> used for parameter edit confirmation, acceptance (confirmation) of the edited parameter value with exit from parameter edit mode
	<p style="text-align: center;">Stop / Reset</p> <p>This button has two integrated operations. The button operates as Stop button for normal operation. In the parameter edit mode it is used to cancel previous action and back-up one step, and in fault mode it is used to reset the fault.</p> <p style="text-align: center;">Stop</p> <ul style="list-style-type: none"> motor STOP from the panel; active control place has to be selected at 'Panel' <p style="text-align: center;">Reset</p> <ul style="list-style-type: none"> used for active fault resetting <ul style="list-style-type: none"> fault history is reset if ENTER is pressed on the 'Fault History' menu group in 'Main Menu' or if ENTER is pressed while in the 'Fault History' menu in programming mode press RESET key to cancel previous action and back up one step
	<p style="text-align: center;">Left Arrow</p> <ul style="list-style-type: none"> navigation button, movement to left in display mode, enter parameter group mode in parameter edit mode, exits mode, backs up one step cancels edited parameter (exit from a parameter edit mode)
	<p style="text-align: center;">Right Arrow</p> <ul style="list-style-type: none"> navigation button, movement to right enter parameter group mode enter parameter mode from group mode
	<p style="text-align: center;">Up and Down Arrows</p> <ul style="list-style-type: none"> move either up or down the group list in order to select the desired group menu. move either up or down the parameter list in order to select the desired parameter in the group. increasing/decreasing of reference value on the keyboard (when selected).
	<p style="text-align: center;">Speed POT</p> <ul style="list-style-type: none"> increase/decrease reference value on the keypad (when selected)

Explanation of Display Messages

Table 2-2

Displayed Message	Descriptions
 60.0	The AC drive Input Frequency Reference.
 60.0	The Actual Operation Frequency at the output terminals T1, T2, and T3.
 2.5	The output current present at the output terminals T1, T2, and T3.
 5.0	The value of the user defined units.
 v 120	The output voltage present at the output terminals T1, T2, and T3.
 t20.0	The temperature of the unit.
 Frd	The AC drive forward run status.
 rev	The AC drive reverse run status.
 20.	Parameter group selection.
 20.05	The specific parameter selection.
 End	“End” displays for approximately 1 second if input has been accepted. After a parameter value has been set, the new value is automatically stored in memory.
 Err	“Err” displays, if the input is invalid.

This page intentionally left blank.

Chapter 3 – Storage and Installation

Storage

The AC drive should be stored in the shipping carton before installation. In order to retain the warranty coverage, the AC drive should be stored properly when it is not to be used for an extended period of time. Some storage suggestions are:

- Store in a clean and dry location free from direct sunlight or corrosive fumes.
- Store within an ambient temperature range of -20 °C to +60 °C.
- Store within a relative humidity range of 0% to 90% and non-condensing environment.
- Store within an air pressure range of 86 kPa to 106kPa.

Environment

Operation

Air Temperature:	
1/2 HP-5HP	-10°C to +50°C (14°F to 122°F),
7.5 HP-10HP	-10°C to +40°C (14°F to 104°F)
Relative Humidity:	0% to 90%, no condensation allowed
Atmosphere pressure:	86 to 106 kPa
Installation Site Altitude:	below 1000m
Vibration:	Maximum 9.80 m/s ² (1G) at less than 20Hz Maximum 5.88 m/s ² (0.6G) at 20Hz to 50Hz

Storage

Temperature:	-20°C to +60°C (-4°F to 140°F)
Relative Humidity:	Less than 90%, no condensation allowed
Atmosphere pressure:	86 to 106

Transportation

Temperature:	-20°C to +60°C (-4°F to 140°F)
Relative Humidity:	Less than 90%, no condensation allowed
Atmosphere pressure:	86 to 106 kPa
Vibration:	Maximum 9.80 m/s ² (1G) at less than 20Hz, Maximum 5.88 m/s ² (0.6G) at 20Hz to 50Hz

Pollution Degree

UL Type 0, Pollution Degree 2:	good for a factory type environment
Relative Humidity:	Less than 90%, no condensation allowed
Atmosphere pressure:	86 to 106

Mounting Area

Improper installation of the AC drive will greatly reduce its life. Be sure to observe the following precautions when selecting a mounting location. **Failure to observe these precautions may void the warranty!**

Do not mount the AC drive near heat-radiating elements or in direct sunlight.

Do not install the AC drive in a place subjected to high temperature, high humidity, excessive vibration, corrosive gases or liquids, or airborne dust or metallic particles.

Mount the AC drive vertically and do not restrict the air flow to the heat sink fins.

The AC drive generates heat. Allow sufficient space around the unit for heat dissipation as shown in the figure below:

Figure 3-1 Mounting in an Enclosure

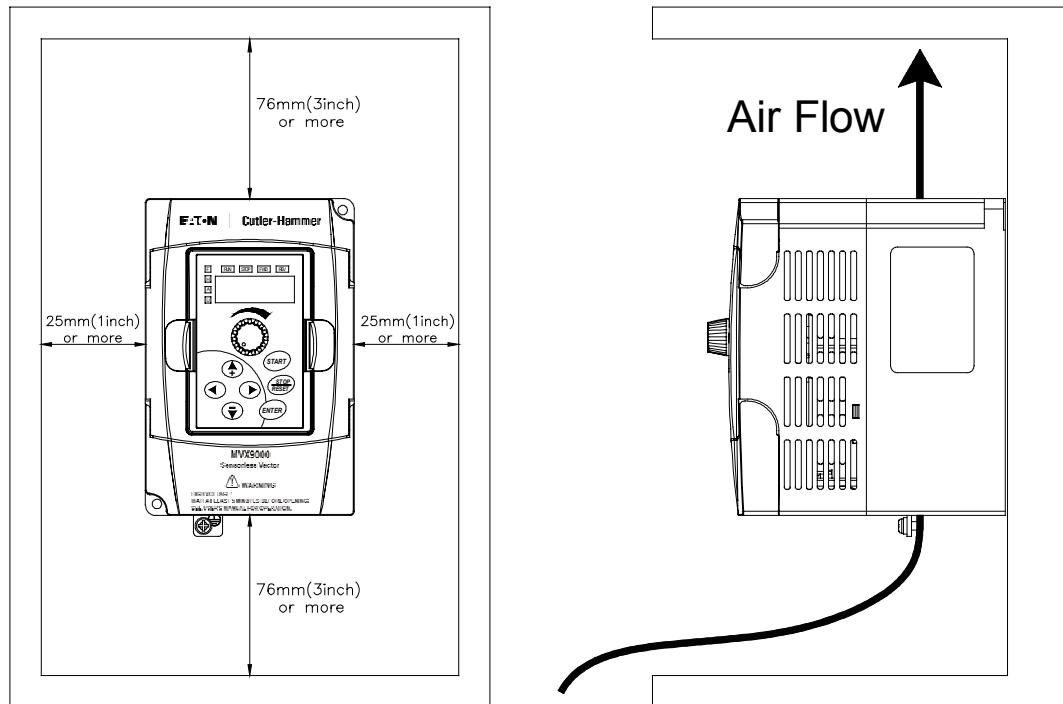

When mounting in an enclosure, allow for the recommended free space. Failure to allow adequate air flow may result in drive over temperature.

Wiring

DANGER!
Hazardous Voltage

Before opening the AC drive covers:

- **Disconnect all power to the AC drive.**

Wait five minutes for DC bus capacitors discharge.

Any Electrical or mechanical modification to this equipment without prior written consent of Eaton Cutler-Hammer will void all warranties and may result in a safety hazard in addition to voiding the UL listing.

Short Circuit Withstand:

Suitable for use on a circuit capable of delivering not more than 5,000 rms symmetrical amperes; for all 460V Models, the maximum is 480 Volts; for all 230V Models, the maximum is 240 Volts.

Applicable Codes

All MVX9000 AC drives are Underwriters Laboratories, Inc. (UL) and Canadian Underwriters Laboratories (cUL) listed, and therefore comply with the requirements of the National Electrical Code (NEC) and the Canadian Electrical Code (CEC).

Installation intended to meet the UL and cUL requirements must follow the instructions provided in "Wiring Notes" as a minimum standard. Follow all local codes that exceed UL and cUL requirements. Refer to the technical data label affixed to the AC drive and the motor nameplate for electrical data.

The "Line Fuse Specification" in Appendix C, lists the recommended fuse part number for each MVX9000 part number. These fuses (or equivalent) must be used on all installations where compliance with U.L. standards is required.

According to the Low Voltage Directive 73/23/EEC and the Amendment Directive 93/68/EEC Digital Keypad, the following AC Motor Drives, MVXF50A0-2, MVX001A0-2, MVX002A0-2, MVX003A0-2, MVX005A0-2, MVX007A0-2, MVX001A0-4, MVX002A0-4, MVX003A0-4, MVX005A0-4, MVX007A0-4, MVX010A0-4, is herewith confirmed to comply with the requirements set out in the Council Directive 73/23/EEC for electrical equipment used within certain voltage limits and the Amendment Directive 93/68/EEC. For the evaluation of the compliance with this Directive, the following standard was applied: EN 50178.

According to the Electromagnetic Compatibility 89/336/EEC and the Amendment Directive 93/68/EEC, the following equipment, AC Motor Drive, MVXF50A0-2, MVX001A0-2, MVX002A0-2, MVX003A0-2, MVX005A0-2, MVX007A0-2, MVX001A0-4, MVX002A0-4, MVX003A0-4, MVX005A0-4, MVX007A0-4, MVX010A0-4, is herewith confirmed to comply with the requirements set out in the Council Directive 89/336/EEC for electromagnetic compatibility and the Amendment Directive 93/68/EEC. For the evaluation of the compliance with this Directive, the following standard was applied: EN61800-3, EN55011, EN50081-2, EN50082-2, EN61000-4-2, EN61000-4-3, EN61000-4-4, EN61000-4-5, EN61000-4-6, EN61000-4-8.

Basic Wiring Diagram

Users must connect wiring according to the following circuit diagram.

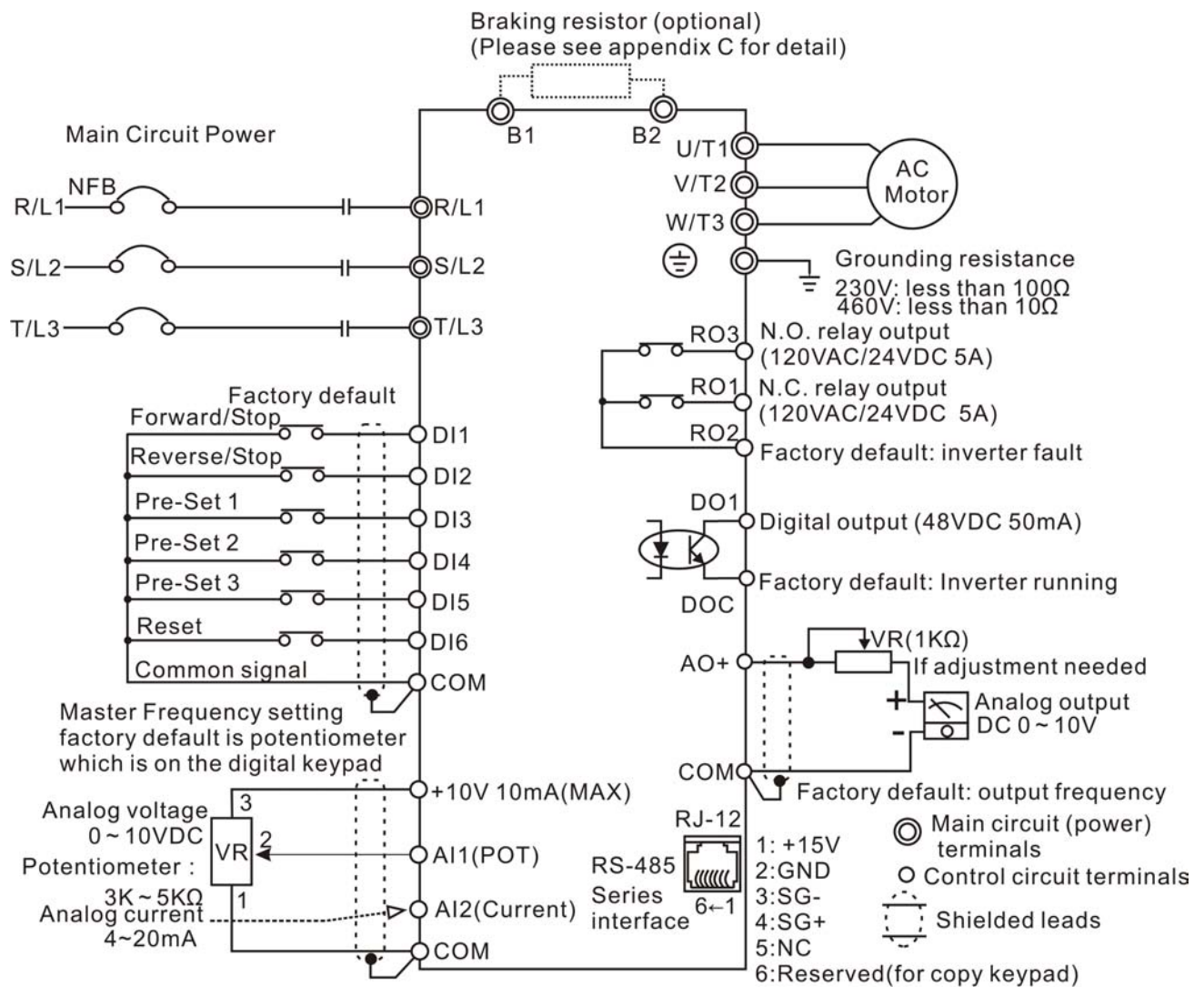

NOTE: Do not plug a Modem or telephone line to the RS-485 communication port, permanent damage may result. Terminal 1 & 2 are the power sources for the optional copy keypad and should not be used while using RS-485 communication.

* 1/2-3hp 230V MVX9000 drives are both single and 3 phase input ready. For single phase input models, select any two input power terminals. For three phase input, use all three input power terminals.

External Wiring

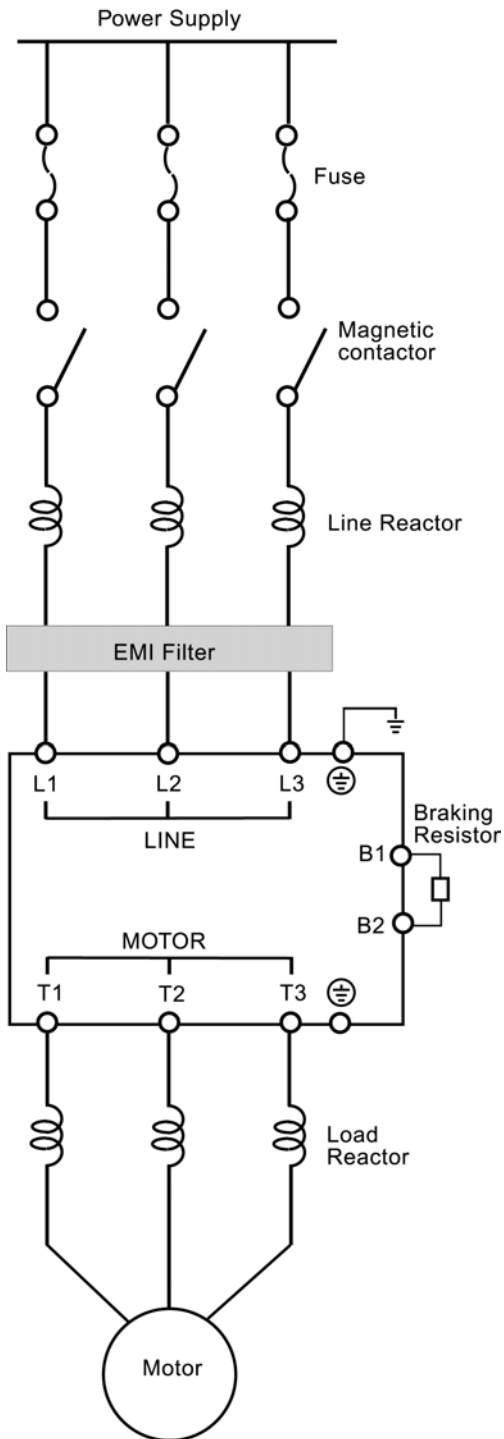

Items	Explanations
Input Power	Please follow the specific power supply requirement shown in Appendix A.
Fuse	Please check the Fuse Specification table in Appendix C for proper fuse selection.
Magnetic contactor (Optional)	Please do not use a Magnetic contactor as the ON/OFF switch of the AC drive, this will reduce the operating life of the AC drive. The contactor should only be used as a safety device for disconnecting power to the drive.
Line/Load Reactor (Optional)	To improve the power factor. An AC Reactor may be necessary when capacity is above 1000kVA, and the wiring distance is within 10m.
EMI filter (Optional)	Used to reduce the electromagnetic interference.
Braking Resistor (Optional)	Used to reduce stopping time of the motor. Please refer to the Braking Resistor table in Appendix C for specific Braking Resistors.

Note: Please refer to Appendix C for more details on the Circuit Breaker and Fuse Specification tables.

Control Terminal Wiring (Factory Settings)

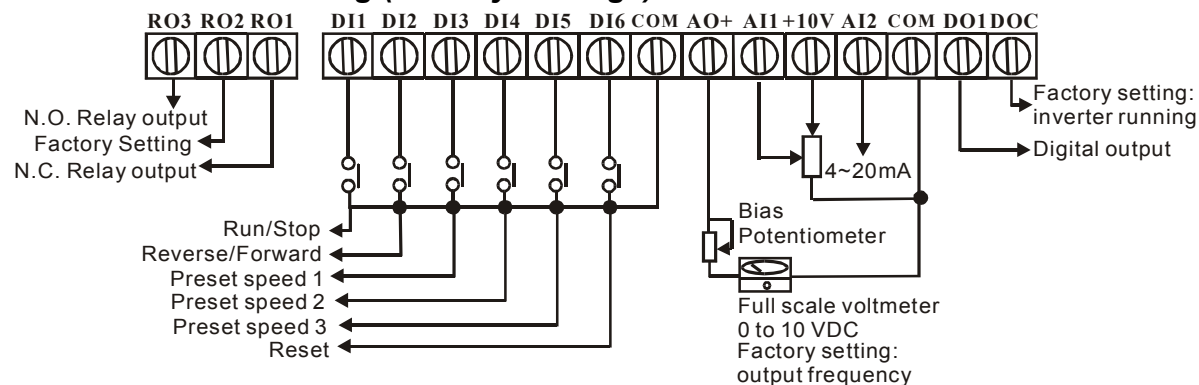

Wire type: 75°C, copper only.

Note: For Wire Gauge and Torque tightening specifications, please refer to the next page.

Table 3-1

Terminal symbols	Terminal name	Remarks
RO1 - RO2	Digital Output Relay	Refer to 40.04 Relay output contact RO1-RO2 (N.C. Contact)
RO3 - RO2	Digital Output Relay	RO3-RO2 (N.O. Contact)
D01 - DCM	Digital photocouple output	Refer to 40.03
RJ - 12	Serial communication port	RS-485 serial communication interface
+10V - COM		Power Supply (+10 V)
AI1 - COM	Analog voltage input	0 to +10 V Input
AI2 - COM	Analog current input	0-20mA or 4 to 20mA Input
AO+ - COM	Analog frequency/current meter	0 to +10 V Output
DI1 - COM	Digital input 1	Refer to 30.11
DI2 - COM to to	Digital input 2 to to	
DI6 - GND	Digital input 6	

Note: Use twisted-shielded, twisted-pair or shielded-lead wires for the control signal wiring. It is recommended to run all signal wiring in a separate steel conduit. The shield wire should only be connected at the drive. Do not connect shield wire on both ends.

Main Circuit Wiring

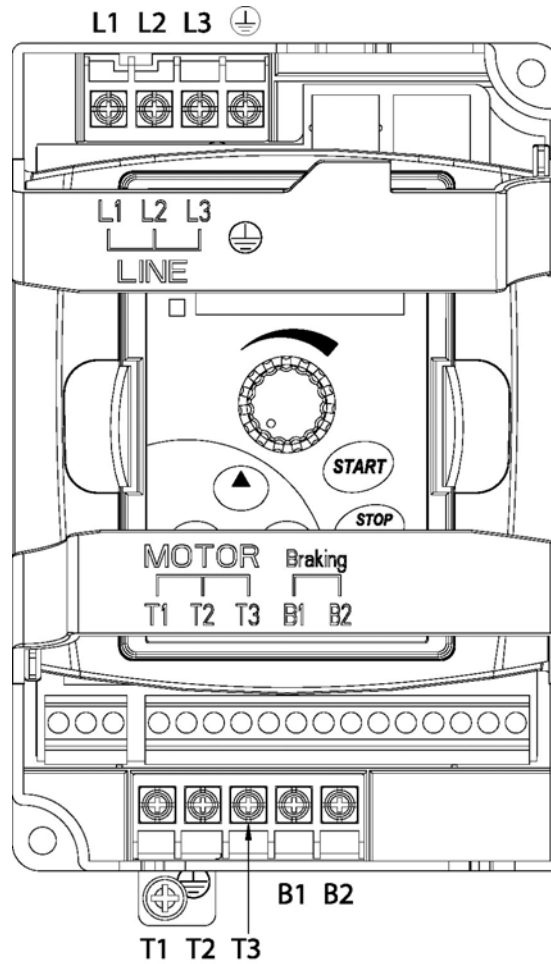

Table 3-2

Wire Type: 75°C Copper Only

Catalog Number	Voltage, Horsepower	Max. Current(A) (Input/Output)	Wire Gauge (AWG)	Torque Rating (kgf-cm)
MVXF50A0-2 (1 phase)	240 VAC, 0.5 Hp	6.3	12-14	14
MVXF50A0-2 (3 phase)	240 VAC, 0.5 Hp	3.2	12-14	
MVX001A0-2 (1 phase)	240 VAC, 1 Hp	11.5	12-14	
MVX001A0-2 (3 phase)	240 VAC, 1 Hp	6.3	12-14	
MVX002A0-2 (1 phase)	240 VAC, 2 Hp	15.7	12	
MVX002A0-2 (3 phase)	240 VAC, 2 Hp	9	12-14	
MVX003A0-2 (1 phase)	240 VAC, 3 Hp	27	8	15
MVX003A0-2 (3 phase)	240 VAC, 3 Hp	15	8-12	
MVX005A0-2	240 VAC, 5 Hp	19.6	8-10	
MVX007A0-2	240 VAC, 7.5 Hp	28	8	14
MVX001A0-4	480 VAC, 1 Hp	4.2	12-14	
MVX002A0-4	480 VAC, 2 Hp	5.7	12-14	
MVX003A0-4	480 VAC, 3 Hp	6	12-14	
MVX005A0-4	480 VAC, 5 Hp	8.5	8-14	
MVX007A0-4	480 VAC, 7.5 Hp	14	8-12	
MVX010A0-4	480 VAC, 10 Hp	23	8-10	15

Wiring Notes

Please read prior to Installation



CAUTION!

Do not connect the AC power to the T1, T2, T3 terminals, it will damage the AC drive.



WARNING!

Make sure that all screws are tightened to the proper torque rating shown in Table 3-2.

- During installation, follow all local electrical, construction, and safety codes for the country in which the drive is installed.
- Make sure that the appropriate protective devices (circuit breaker or fuses) are connected between the power supply and AC drive.
- Make sure that the leads are connected correctly and the AC drive is properly grounded.
- Use ground leads that comply with AWG/MCM standards and keep them as short as possible.
- Multiple MVX9000 units can be installed in one location. All the units should be grounded directly to a common ground terminal. The MVX9000 ground terminals may also be connected in parallel, as shown in the figure below. **Make sure there are no ground loops.**

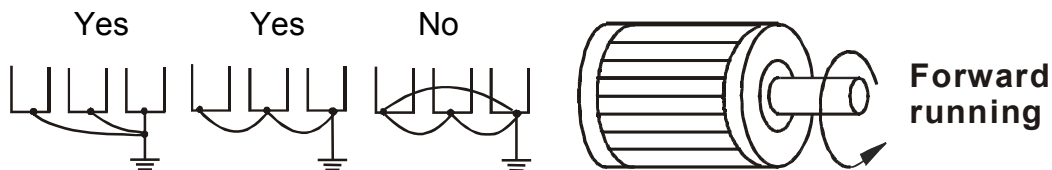

- When the AC drive output terminals U/T1, V/T2, and W/T3 are connected to the motor terminals T1, T2, and T3, respectively, the motor will rotate counterclockwise (as viewed from the shaft ends of the motor) when a forward operation command is received. To reverse the direction of motor rotation, switch over any of the two motor leads.
- Make sure that the power source is capable of supplying the correct voltage and required current to the AC drive.
- Do not attach or remove wiring when power is applied to the AC drive.
- Do not inspect components unless the inside “POWER” lamp has turned off.

- Do not monitor the signals on the circuit board while the AC drive is in operation.
- For the single-phase rated AC drives, the AC power can be connected to any two of the three input terminals R/L1, S/L2, T/L3. Note: This drive is not intended for the use with single-phase motors.
- Route the power and control wires separately, or at a 90 degree angle to each other.
- If a filter is required for reducing EMI (Electro Magnetic Interference), install it as close as possible to the AC drive. EMI can also be reduced by lowering the Carrier Frequency.
- If the AC drive is installed in the place where a load reactor is needed, install the filter close to U/T1, V/T2, W/T3 side of AC drive. Do not use a Capacitor or L-C Filter (Inductance-Capacitance) or R-C Filter (Resistance-Capacitance), unless approved by Cutler-Hammer.
- When using a GFCI (Ground Fault Circuit Interrupt), select a current sensor with sensitivity of 200mA, and not less than 0.1-second detection to avoid nuisance tripping.

Motor Operation Precautions

- When using the AC drive to operate a standard 3-phase induction motor, notice that the energy loss is greater than for an inverter duty motor.
- Avoid running a standard induction motor at low speed. Under these conditions, the motor temperature may rise above the motor rating due to limited airflow produced by the motor's fan.
- When the standard motor operates at low speed, the output load must be decreased.
- If 100% output torque is desired at low speed, it may be necessary to use a special "inverter-duty" rated motor.

This page intentionally left blank.

Chapter 4 – Start-up Procedures

This chapter will explain the installation of the MVX9000 Microdrive. Be sure to read and follow all instructions for a successful installation.



WARNING!

This equipment should be installed, adjusted, and serviced by qualified electrical maintenance personnel familiar with the construction and operation of the equipment and the hazards involved. Failure to observe this precaution could result in bodily injury.

Step-by-Step Installation

1. Read all instructions and warnings associated with mounting the MVX9000.
2. Select a suitable mounting location.
3. Check the inverter mounting dimensions for footprint and mounting hole locations.
4. Connect the wiring for the inverter input.
5. Connect the wiring to the motor.
6. Perform a power-up test.
7. Make observations and re-check the installation.

Mounting Location

Step 1: Study the following caution messages associated with mounting the inverter.



CAUTION!

Be sure to install the unit on flame-resistant material such as a steel plate. Otherwise, there is the danger of fire.



CAUTION!

Be sure to install the unit on a perpendicular wall which is not subject to vibration. Otherwise, it may fall and cause injury to personnel.



CAUTION!

Be sure not to let the foreign matter enter vent openings in the inverter housing, such as wire clippings, spatter from welding, metal shavings, dust, etc. Otherwise, there is the danger of fire.



CAUTION!

Be sure not to install or operate an inverter which is damaged or has missing parts. Otherwise, it may cause injury to personnel.



CAUTION!

Be sure to install the inverter in a well-ventilated room which does not have direct exposure to sunlight, a tendency for high temperature, high humidity or dew condensation, high levels of dust, corrosive gas, explosive gas, inflammable gas, grinding-fluid mist, salt damage, etc. Otherwise, there is the danger of fire.

Step 2: The installation should be made on a solid, non-flammable, vertical surface that is a relatively clean and dry environment. In order to ensure enough room for air circulation around the inverter to aid in cooling, maintain the specified clearance around the inverter specified in the diagram.

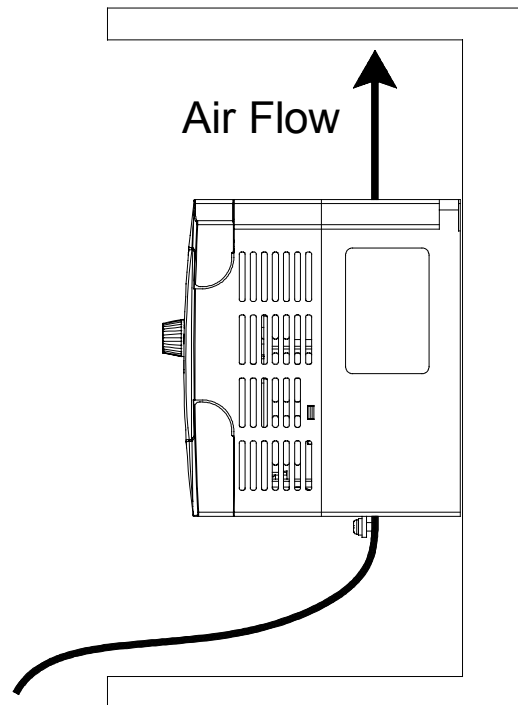
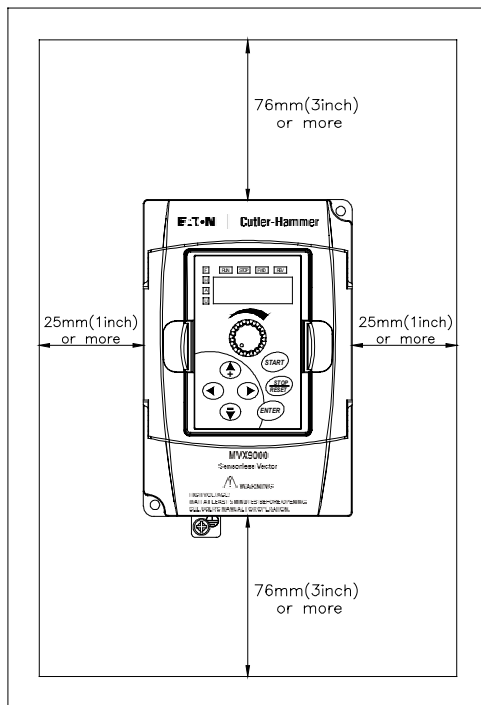

Please observe this checklist while mounting the inverter:

- The ambient temperature must be in the range of –10 to 50°C (1/2 to 5hp).
- The ambient temperature must be in the range of –10 to 40°C (7.5 to 10hp). If the range will be up to 50°C, set the carrier frequency to 2.1 kHz or less and derate the output current to 80% or less. Chapter 5 covers how to change parameters such as the carrier frequency.
- Keep any other heat-producing equipment as far away from the inverter as possible.
- When installing the inverter in an enclosure, maintain the clearance around the inverter and verify that its ambient temperature is within specification when the enclosure door is closed.
- Do not open the main front panel door at any time during operation.

Step 3: Before proceeding to the wiring section, *temporarily* cover the inverter's ventilation openings. Paper and masking tape is all that is needed to do this. This will prevent harmful debris such as wire clippings and metal shavings from entering the inverter during installation.

Inverter Mounting

Step 4: Locate the applicable drawing in the Appendix for the inverter unit. Dimensions are given in inches (millimeters) format.

Note: *Some inverter housings require two mounting screws, while others require four. Be sure to use lock washers or other means to ensure screws do not loosen due to vibration.*

Wiring Preparation

Step 5: It is very important to perform the wiring steps carefully and correctly. Before proceeding, please study the caution and warning messages below.



WARNING!

“Use 75°C Cu wire only” or equivalent.



WARNING!

“Suitable for use on a circuit capable of delivering not more than 5,000 rms symmetrical amperes, 240 V maximum.” For models with suffix B.



WARNING!

“Suitable for use on a circuit capable of delivering not more than 5,000 rms symmetrical amperes, 480 V maximum.” For models with suffix C.



HIGH VOLTAGE!

Be sure to ground the unit. Otherwise, there is danger of electric shock and/or fire.



HIGH VOLTAGE!

Wiring work shall be carried out only by qualified personnel. Otherwise, there is a danger of electric shock or fire.

Wire and Fuse Sizes

The maximum motor currents in the application determine the recommended wire size. The following table gives the wire size in AWG. The Power/Motor column applies to the inverter input power, output wires to the motor, the ground connection, and any other component shown in the system wiring diagram. The “Signal Lines” column applies to any wire connecting to the External I/O Connection inside the bottom front panel half-door.

Table 4-1 Wire Size

Motor Output (kW/HP)		Inverter Model	Wiring	
kW	HP		Power Lines	Signal Lines
0.4	1/2	MVXF50A0-2	AWG14 / 2.1 mm ²	(*) 18 to 20 AWG / 0.14 to 0.75 mm ² shielded wire
.75	1	MVX001A0-2	AWG14 / 2.1 mm ²	
1.5	2	MVX002A0-2 (1 phase)	AWG12 / 3.3 mm ²	
1.5	2	MVX002A0-2 (3 phase)	AWG14 / 2.1 mm ²	
2.2	3	MVX003A0-2 (1 phase)	AWG 8 / 8.4 mm ²	
2.2	3	MVX003A0-2 (3 phase)	AWG12 / 3.3 mm ²	
3.7	5	MVX005A0-2	AWG10 / 5.3 mm ²	
5.5	7-1/2	MVX007A0-2	AWG8 / 8.4 mm ²	
0.75	1	MVX001A0-4	AWG14 / 2.1 mm ²	
1.5	2	MVX002A0-4		
2.2	3	MVX003A0-4		
4.0	5	MVX005A0-4	AWG14 / 2.1 mm ²	
5.5	7-1/2	MVX007A0-4	AWG12 / 3.3 mm ²	
7.5	10	MVX010A0-4	AWG10 / 5.3 mm ²	

Note 1: Field wiring must be made by a UL-listed and CSA-certified closed-loop terminal connector sized for the wire gauge involved.

Note 2: Be sure to consider the capacity of the circuit breaker to be used.

Note 3: Be sure to use larger wires for the power lines in the distance exceeds 20 meters.

Table 4-2 Fuse Specification Chart

Smaller fuses than those shown in the table are permitted.

Model	Input Current (A)	Output Current (A)	Line Fuse	
			I (A)	Bussmann P/N
MVXF50A0-2 (1 phase)	6.3	2.5	25	JJN-25
MVXF50A0-2 (3 phase)	3.2	2.5	10	JJN-10
MVX001A0-2 (1 phase)	11.5	5	45	JJN-45
MVX001A0-2 (3 phase)	6.3	5	20	JJN-20
MVX002A0-2 (1 phase)	15.7	7	60	JJN-60
MVX002A0-2 (3 phase)	9	7	25	JJN-25
MVX003A0-2 (1 phase)	27	10	100	JJN-100
MVX003A0-2 (3 phase)	15	10	40	JJN-40
MVX005A0-2	19.6	17	60	JJN-60
MVX007A0-2	28	25	100	JJN-100
MVX001A0-4	4.2	3	10	JJS-10
MVX002A0-4	5.7	4	15	JJS-15
MVX003A0-4	6	5	20	JJS-20
MVX005A0-4	8.5	8.2	30	JJS-30
MVX007A0-4	14	13	50	JJS-50
MVX010A0-4	23	18	70	JJS-70

Recommended Fuses for UL approval

Equivalent fuse types = J class, CC class, T class and Type BS88 with a 600V limit.

Table 4-3 Heat Loss Data

When mounting the MVX9000 in an enclosure the following inverter heat loss should be considered. Failure to provide adequate cooling may cause premature failure of the inverter and/or overtemperature faults.

Model	Watts Lost at 9 kHz
MVXF50A0-2 (1 phase)	20
MVXF50A0-2 (3 phase)	20
MVX001A0-2 (1 phase)	38
MVX001A0-2 (3 phase)	38
MVX002A0-2 (1 phase)	75
MVX002A0-2 (3 phase)	75
MVX003A0-2 (1 phase)	110
MVX003A0-2 (3 phase)	110
MVX005A0-2	185
MVX007A0-2	275
MVX001A0-4	38
MVX002A0-4	75
MVX003A0-4	110
MVX005A0-4	185
MVX007A0-4	275
MVX010A0-4	375

Wiring the Inverter to Incoming Power

Step 6: In this step, connect the wiring to the input of the inverter. First determine whether the inverter model requires three-phase power only, or if it can accept either single-phase or three-phase power. All models have the same power connector terminals labeled L1, L2, L3 and  (Ground). **Refer to the specifications label (on the side of the inverter) for the acceptable power source types! For inverters which can accept single-phase power, use terminals L1 and L2.**



CAUTION!

Be sure that the input voltage matches the inverter specifications:

- Single/Three phase 200 to 240 V 50/60 Hz (up to 2.2kW)
- Three phase 200 to 230 V 50/60 Hz (above 2.2kW)
- Three phase 380 to 460 V 50/60 Hz



CAUTION!

Be sure not to connect an AC power supply to the output terminals. Otherwise, there is the danger of injury and/or fire.

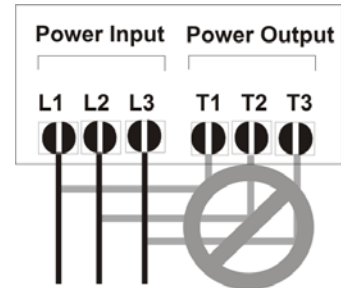

Note:

L1, L2, L3: Three-phase 200 to 230V 50/60 Hz
 Three-phase 380 to 460V 50/60 Hz

Any two inputs: Single-phase 200 to 240V 50/60 Hz

Wiring the Motor to the Inverter Output

Step 7: Connect the three phase AC induction motor to the output of the inverter. The motor must be a three phase induction motor. It should also come with a chassis ground lug. If the motor does not have three power input leads, stop the installation and verify the motor type. Other guidelines for wiring the motor include:

- Use an inverter-grade motor for maximum motor life (1600 V insulation).
- For standard motors, use the AC reactor accessory if the wiring between the inverter and motor exceeds 30 feet (10 meters) in length.

Connect the motor to the terminals indicated on the inverter. The terminals are labeled T1, T2, and T3. Connect the chassis ground lug on the inverter. The motor chassis ground must also connect to the same point. Use a star ground (single point) arrangement, and never daisy-chain the grounds (point-to-point).

Use the same wire gauge on the motor and chassis ground wiring as you used on the power input wiring in the previous step. After completing the wiring:

- Check all wire connections both at the inverter and motor to make sure they are secure.
- Close all access doors.
- Remove any covering placed on the inverter ventilation openings.

Powerup Test

Step 8: After wiring the inverter and motor, perform a powerup test. The procedure that follows is designed for the first-time use of the drive. Verify the following conditions before conducting the powerup test:

- The previous steps in this chapter have been followed.
- The inverter is new, and securely mounted to a non-flammable vertical surface.
- The inverter is connected to a power source and motor.
- No additional wiring of the inverter connectors or terminals has been done.
- The power supply is reliable, and the motor is a known working unit.
- The motor is mounted, and is not connected to any load.

The following instructions apply to the powerup test, or to any time the inverter is powered and operating. Please study the following instructions and messages before proceeding with the powerup test.

1. The power supply must have fusing suitable for the load. Check the fuse size chart presented in Step 5 if necessary.
2. Be sure you have access to a disconnect switch for the drive input power if necessary. However, do not turn off power to the inverter during its operation unless it is an emergency.
3. Turn the inverter's front panel potentiometer to the *MIN* position (fully counterclockwise).



CAUTION!

The operation of the inverter can be easily changed from low speed to high speed. Be sure to check the capability and limitations of the motor and machine before operating the inverter. Otherwise, there is the danger of injury.



CAUTION!

If you operate a motor at a frequency higher than the inverter standard default setting (50Hz/60Hz), be sure to check the motor and machine specifications with the respective manufacturer. Only operate the motor at elevated frequencies after getting their approval. Otherwise, there is the danger of equipment damage.

Powering the Inverter

If you have followed all the steps, cautions and warnings up to this point, you're ready to apply power. After doing so, the following events should occur:

- The numeric (7-segment) LEDs will illuminate.
- The Hz, Stop and Fwd LEDs will illuminate.

If the motor starts running unexpectedly or any other problem occurs, press the *STOP* button. Only if necessary should you remove power to the inverter as a remedy.

Note: *If the inverter has been previously powered and programmed, the LEDs (other than the POWER LED) may illuminate differently than as indicated above. If necessary, you can initialize all parameters to the factory default settings. See the initialization instructions in the Programming section.*

Chapter 5 – Descriptions of Parameter Settings

This chapter contains the descriptions of the MVX9000 parameters. Parameters are addressed and changed via the keypad for the MVX9000. For more information on keypad operation, see Keypad Operation located in Chapter 2.

Parameters are grouped in a page arrangement. Each page will contain a list of the parameters associated with that group. Move into the page groups from the display menu by using the right arrow key.

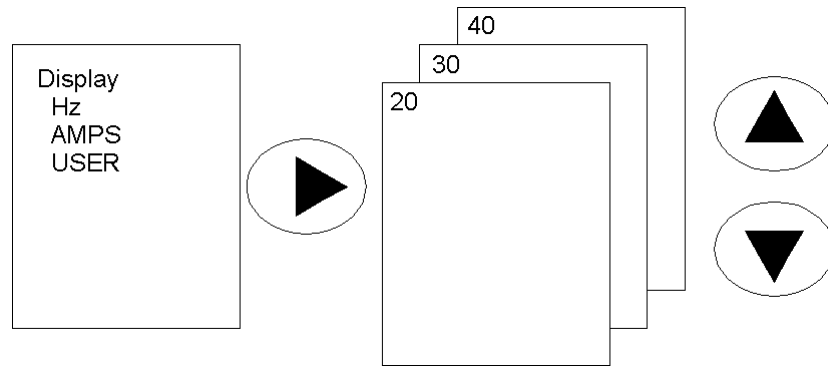

Select the desired parameter group by using the up and down keys. Once the parameter group is located, use the right arrow key to enter the group. Use the up and down keys to scroll the parameters on that page.

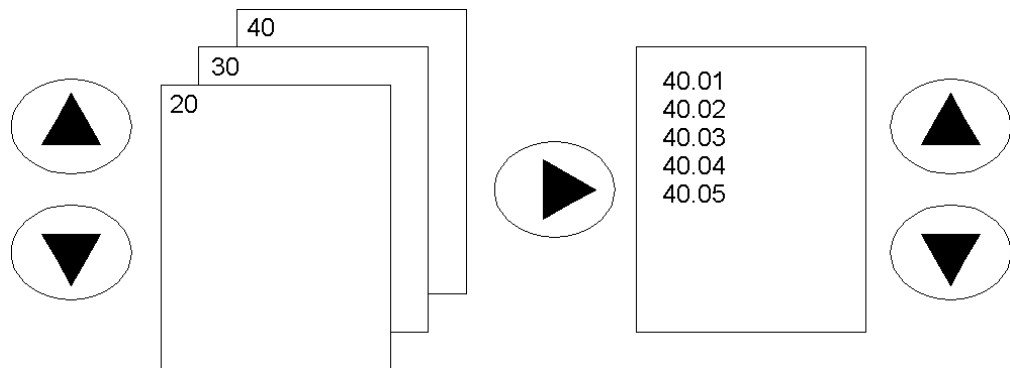

Once the parameter has been located, use the right arrow key to view the parameter setting.

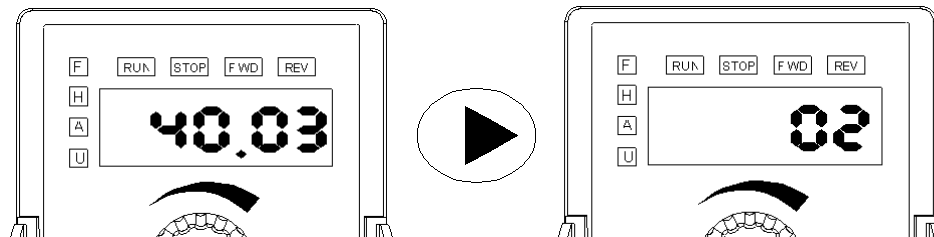

Use the ENTER key to enter the programming mode. The displayed parameter will flash indicating the parameter can be changed.

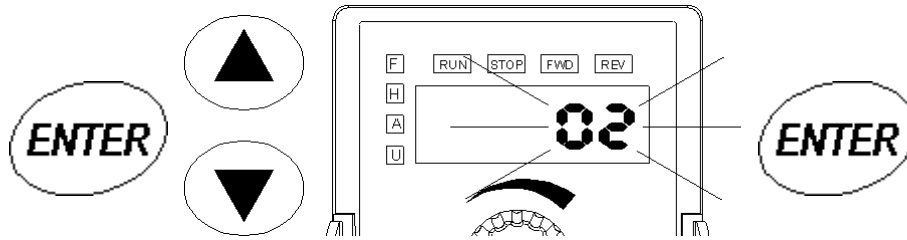

Use the up and down keys to change the parameter setting. Press ENTER to enter the new parameter setting.

If the parameter change is successful, the keypad will display the END message and return to the parameter number display. If the parameter change is unsuccessful the keypad will display an error (Err) message, the parameter will not be changed, and the parameter number will again be displayed.

Note: some parameters cannot be changed while in the Run/Start mode.

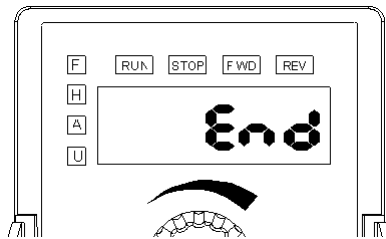

**Successful
Parameter Change**



**Unsuccessful
Parameter Change**

To exit the programming mode, press the left arrow key to return to the display mode.

Parameter Groups

The parameters are grouped according to the following descriptions:

10 Reserved (and not displayed)	
20 Basic Grouping (Start Up)	5-4
30 Inputs.....	5-6
40 Outputs.....	5-24
50 AC Drive Control	5-28
60 Motor Control.....	5-45
70 Protective Functions	5-49
80 Display.....	5-54
90 Communications.....	5-58

Group 20 — Basic Grouping (Quick Start)

20.01
Motor Nameplate Frequency Range: 10.0 to 400.0Hz Default: 60.0
Unit: 0.1Hz

This value should be set according to the rated frequency of the motor as indicated on the motor nameplate. Motor nameplate Frequency determines the volts/hertz ratio.

For example: if the drive is rated for 460 VAC output and the Motor nameplate Frequency is set to 60Hz, the drive will maintain a constant ratio of 7.66 v/Hz. **The setting value must equal to or greater than the Mid-Point Frequency (50.07).**

20.02
Motor Nameplate Voltage Range: 230V series 2.0 to d 255V Default: 230.0
Range: 460V series 2.0 to d 510V Default: 460.0

This parameter determines the motor nameplate voltage of the AC drive. The motor nameplate voltage setting must be smaller than or equal to the rated voltage of the motor as indicated on the motor nameplate. **The setting value must equal to or greater than the Mid-Point Voltage (50.08).**

20.03
Source of Master Frequency Range: Default: 01
00 Master Frequency determined by digital keypad on the drive.
01 Master Frequency determined by keypad potentiometer.
02 Master Frequency determined by 0-10V on terminal AI1.
03 Master Frequency determined by 4-20mA on terminal AI2.
04 Master Frequency determined by RS485.

20.04
Source of Operation Command Range: Default: 00
00 Operating commands determined by the Digital Keypad.
01 Operating commands determined by the External Control Terminals. Keypad STOP key is enabled.
02 Operating commands determined by the External Control Terminals. Keypad STOP key is not enabled.
03 Operating commands determined by the RS-485 communication interface. Keypad STOP key is enabled.
04 Operating commands determined by the RS-485 communication interface. Keypad STOP key is not enabled.

20.05
Motor Rated Current

Default: xx.x A

Enter the motor's nameplate rated amps.
 The value must be between 30 to 120% of the drive's rated output current. This parameter sets the drive's output current limit.
 This parameter may be set during operation.

20.06
**Minimum Output
 Frequency**

Range: 0.1 to 20.0Hz

Default: 1.5

Unit: 0.1Hz

This parameter sets the Minimum Output Frequency of the AC drive. This parameter must be equal to or less than the Mid-Point Frequency (50.07).

20.07
**Maximum Output
 Frequency**

Range: 50.0 to 400.0 Hz

Default: 60.0

Unit: 0.1Hz

This parameter determines the AC drive's Maximum Output Frequency. All the AC drive accelerations and decelerations are scaled to correspond to this maximum output frequency.

20.08 / 20.09
Acceleration Time 1
Deceleration Time 1

Range: 0.01 to 600.00 sec

Default: 10.00 sec

Unit: 0.01 second

These parameters may be set during operation.

20.08 is used to determine the time required for the AC drive to ramp from 0 Hz to its Maximum Output Frequency (20.07). The rate is linear unless S-Curve is "Enabled."

20.09 is used to determine the time required for the AC drive to decelerate from the Maximum Output Frequency (20.07) down to 0 Hz. The rate is linear unless S-Curve is "Enabled."

Group 30 — Inputs

30.01
Minimum Reference Value (0-10V) Range: 0.0 to 10.0 V Default: 0.0
Unit: 0.1

This parameter sets the analog voltage input value referenced to the Minimum Output Frequency (50.09).

30.02
Maximum Reference Value (0-10V) Range: 0.0 to 10.0 V Default: 10.0
Unit: 0.1

This parameter sets the analog voltage input value referenced to the Maximum Output Frequency (50.04).

30.03
Invert Reference Signal (0-10V) Range: Default: 00
00: Not inverted
01: Inverted

30.04
Minimum Reference Value (4-20mA) Range: 0.0 to 20.0 mA Default: 4.0
Unit: 0.1

This parameter sets the analog current input value referenced to the Minimum Output Frequency (50.09).

30.05
Maximum Reference Value (4-20mA) Range: 0.0 to 20.0 mA Default: 20.0
Unit: 0.1

This parameter sets the analog current input value referenced to the Maximum Output Frequency (50.04).

30.06
Invert Reference Signal (4-20mA) Range: Default: 00
00: Not inverted
01: Inverted

30.07
Potentiometer Offset Range: 0.0 to 100.0% Default: 0.0 %
 Unit: 0.1%

This parameter may be set during operation.

This parameter provides a frequency offset for the analog input.

Example: Potentiometer Offset = (10hz/60hz) x 100

30.08
Potentiometer Bias Range: Default: 00
Polarity 00 Positive Bias
 01 Negative Bias

This parameter may be set during operation.

This parameter sets the Potentiometer Bias Frequency to be positive or negative.

30.09
Potentiometer Slope Range: 0.1 to 300.0% Default: 100.0
 Unit: 0.1%

This parameter may be set during operation.

This parameter sets the slope (or ratio) of analog input vs. output frequency.

Example: Potentiometer Slope = (1-30.07) x 100% = 83.3%

30.10
Potentiometer Direction Range: Default: 00
 00 Forward motion only
 01 Reverse motion enable (must be in negative bias)

This parameter allows the user to select direction via the analog input command. Setting of 01 allows both forward and reverse direction as shown in example 5 below.

The above parameters (Pr. 30.07 to 30.10) are used when the source of frequency command is the analog input AI1, AI2, or keypad potentiometer (0 to +10V DC or 4 to 20mA DC). Refer to the following examples for programming these parameters.

Example 1:

This example shows a standard 0-10V analog input (either from the keypad potentiometer or an external source). A 0V input = 0Hz and 10V input = maximum output frequency.

Defaults:

- 20.07=60Hz Maximum Output Frequency
- 30.07=0% Potentiometer Offset
- 30.08=0 Bias polarity
- 30.09=100% Potentiometer slope
- 30.10=0 Potentiometer direction

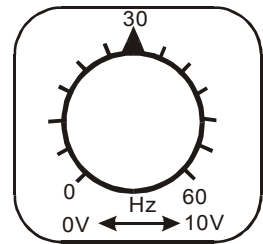
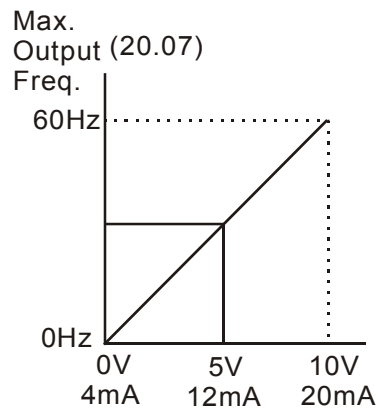

Potentiometer Scale

Example 2:

This example shows a 10Hz positive offset with full use of the 0-10V analog input or potentiometer scale. A 0V input = 10Hz and 10V input = maximum output frequency.

Defaults:

- 20.07=60Hz Maximum Output Frequency
- 30.07=16.7% $(10\text{hz}/60\text{hz}) \times 100$ =Potentiometer Offset
- 30.08=0 Bias polarity
- 30.09=83.3% Potentiometer Slope
- 30.10=0 Potentiometer Direction

Calculation of Potentiometer Slope

$$30.09 = (1 - 30.07) \times 100\% = 83.3\%$$

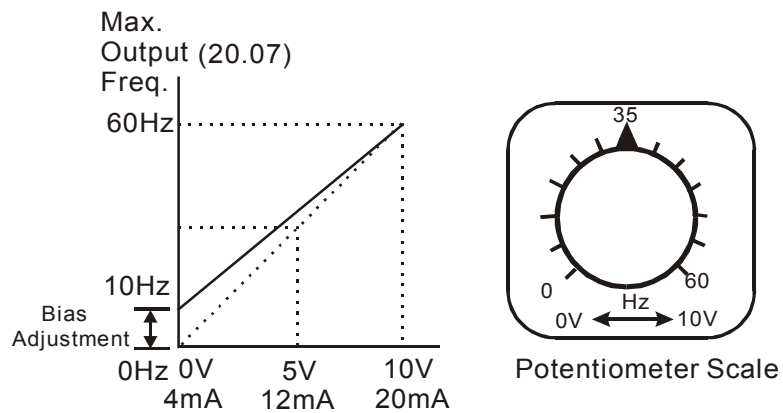

Example 3:

This example shows an analog command range of 0 to 5 Volts, with an output of 0Hz to Maximum Output Frequency.

Defaults:

- 20.07=60Hz Maximum Output Frequency
- 30.07=0% Potentiometer Offset
- 30.08=0 Bias polarity
- 30.09=200% Potentiometer Slope
- 30.10=0 Potentiometer direction

Calculation of gain

$$30.09 = \left(1 - \frac{10V}{5V}\right) \times 100\% = 200\%$$

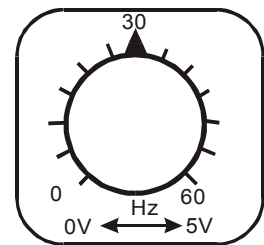
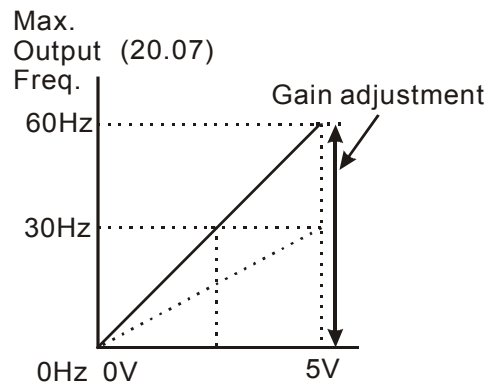

Potentiometer Scale

Example 4:

In this example a 1-volt negative bias is used. In a noisy environment, it is advantageous to use negative bias to provide a noise margin (1V in this example).

Defaults:

- 20.07=60Hz Maximum Output Frequency
- 30.07=10% $(6/60) \times 100\%$ = Potentiometer Offset
- 30.08=1 Bias polarity
- 30.09=100% Potentiometer Slope
- 30.10=0 Potentiometer Direction

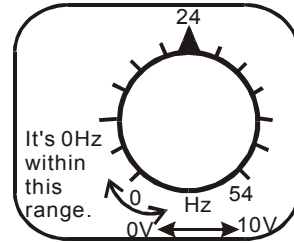
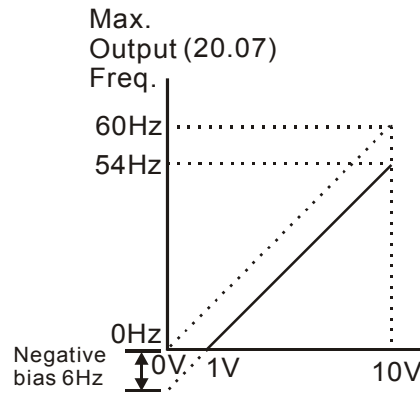

Potentiometer Scale

Example 5:

In this example, the analog input or potentiometer is programmed to run a motor in both the forward and reverse directions. A motor will be idle (0hz) when the analog input or potentiometer is at the mid-point of its scale.

Defaults:

- 20.07=60Hz Maximum Output Frequency
- 30.07=100% Potentiometer Offset
- 30.08=1 Bias polarity
- 30.09=200% Potentiometer Slope
- 30.10=1 Potentiometer Direction

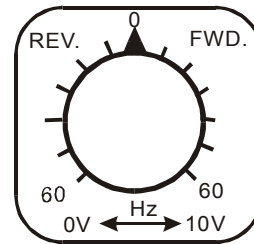
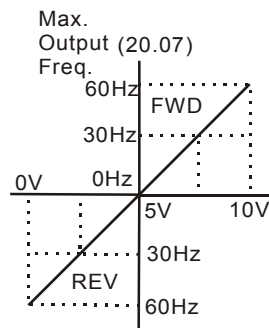

Potentiometer Scale

30.11
Digital Input Terminal
(DI1, DI2)

Range: Default: 02

01 DI1: FWD / STOP
 DI2: REV / STOP

02 Two Wire Operation mode
 DI1: RUN / STOP
 DI2: REV / FWD

03 3-Wire Operation mode
 DI1: RUN
 DI2: REV / FWD
 DI3: STOP

Setting 01

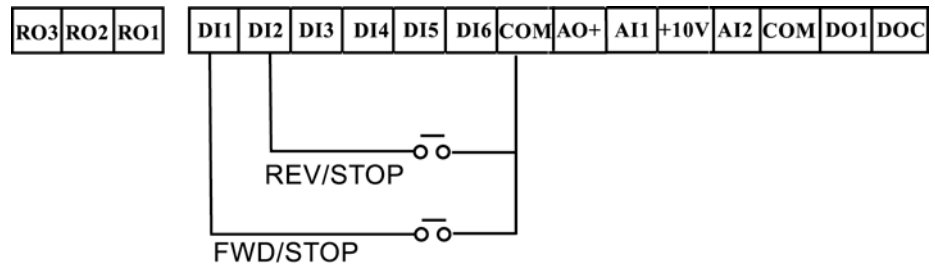

Setting 02

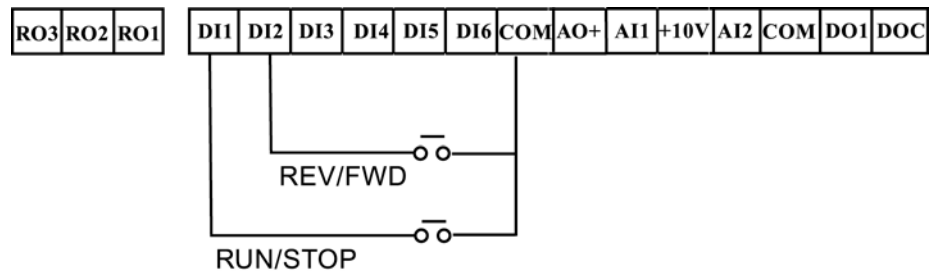

Setting 03

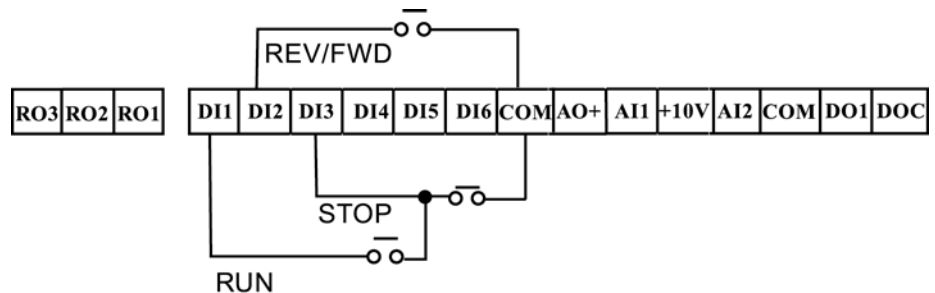

30.12		
Digital Input Terminal (DI3)	Range:	Default: 05
	00	Not Used
	01	External Fault (N.O.)
	02	External Fault (N.C.)
	03	External Reset (N.O.)
	04	External Reset (N.C.)
	05	Preset Speed Switch 1
	06	Preset Speed Switch 2
	07	Preset Speed Switch 3
	08	Jog
	09	2 nd Acceleration/Deceleration time selection
	10	Control Location - I/O terminals
	11	Control Location - keypad
	12	Control Location - communication
	13	Increase Master Frequency
	14	Decrease Master Frequency
	15	Forward / Reverse
	16	Parameter Lock
	17	Acceleration / Deceleration Inhibit
	18	Run Enable
	19	PAUSE (N.O.)
	20	PAUSE (N.C.)
	21	PID Disable
	22	Run PLC
	23	Pause PLC
	24	Counter input
	25	Counter reset
	26	First / Second source of Master Frequency

30.13
Digital Input Terminal (DI4) Range: See Parameter 30.12 Default: 06

30.14
Digital Input Terminal (DI5) Range: See Parameter 30.12 Default: 07

30.15
Digital Input Terminal (DI6) Range: See Parameter 30.12 Default: 03

Explanations:
 Digital Input Terminal
 Settings 01,02

When an External Fault input signal is received, the AC drive output will turn off, the drive will display “E.F” on digital keypad, and the motor will coast to a stop. Normal operation will resume after the External Fault is cleared and the AC drive is reset.

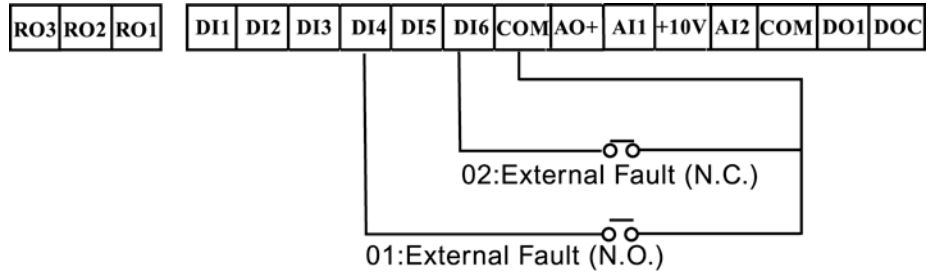

Settings 03,04

The External Reset has the same function as the Reset key on the Digital keypad. It is used to reset the drive after a fault.

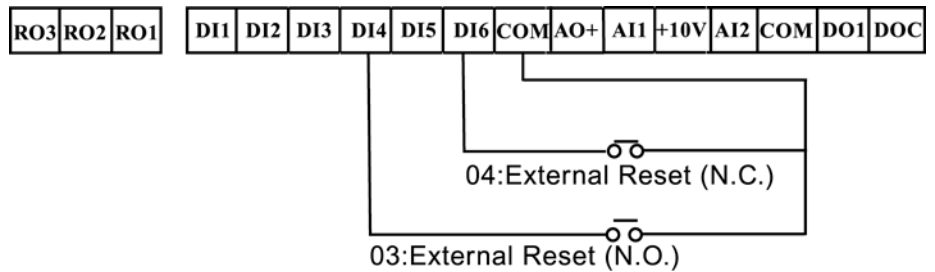

Settings 05, 06, 07

These three inputs select the preset speeds defined by P30.18 to P30.24.

	Switch 1	Switch 2	Switch 3
P 30.18	ON	OFF	OFF
P 30.19	OFF	ON	OFF
P 30.20	ON	ON	OFF
P 30.21	OFF	OFF	ON
P 30.22	ON	OFF	ON
P 30.23	OFF	ON	ON
P 30.24	ON	ON	ON

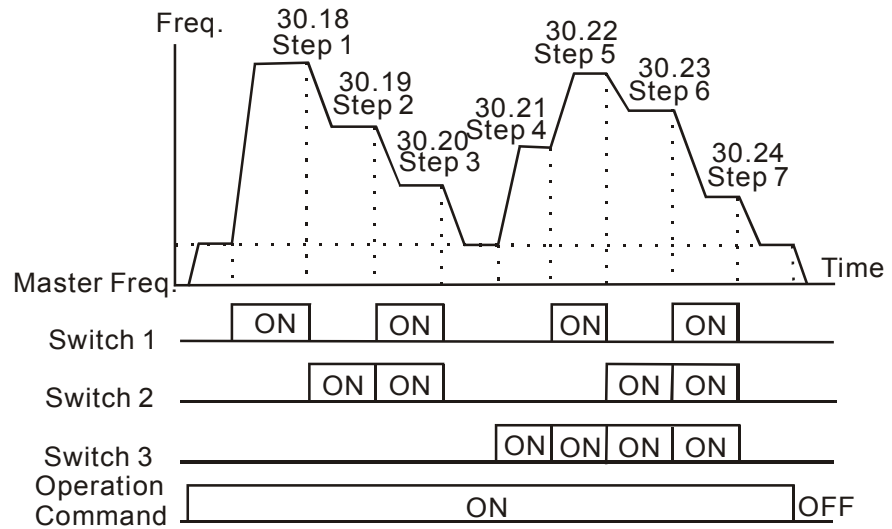
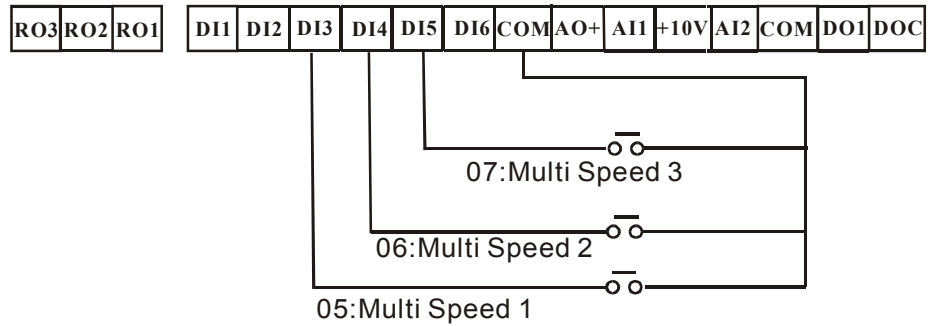

Setting 08

Jog operation may only be initiated while the motor is stopped. (Refer to P50.20, P50.21)

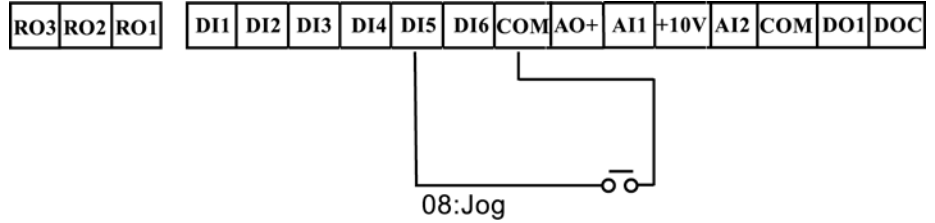

Setting 09

Digital input terminals (DI3-DI6) may be used to change from the first to the second accel/decel time.

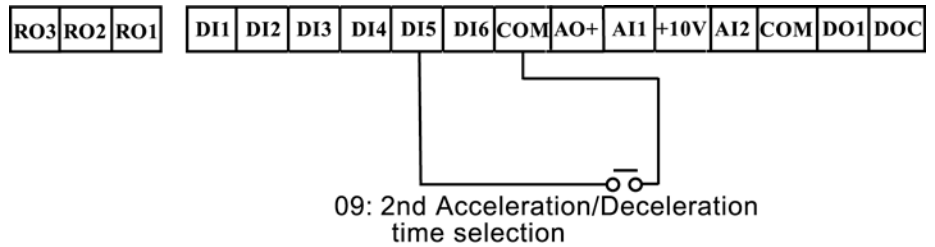

Settings 10, 11, 12

Used to select the Operation Command location of the AC drive.

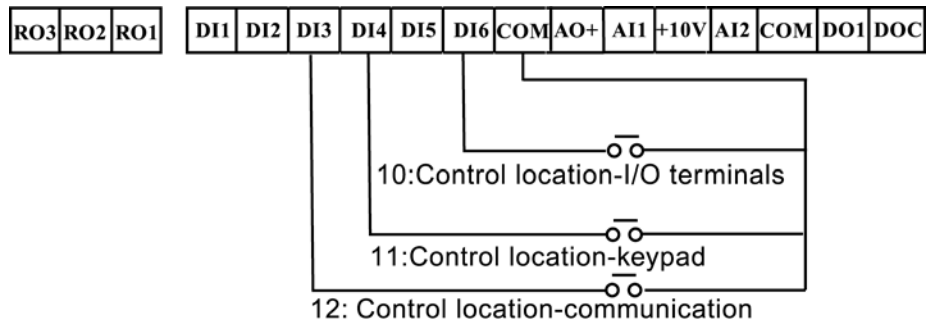

Settings 13, 14

Setting 13 and 14 enables the digital input terminal to incrementally increase/decrease the Master Frequency each time an input is received.

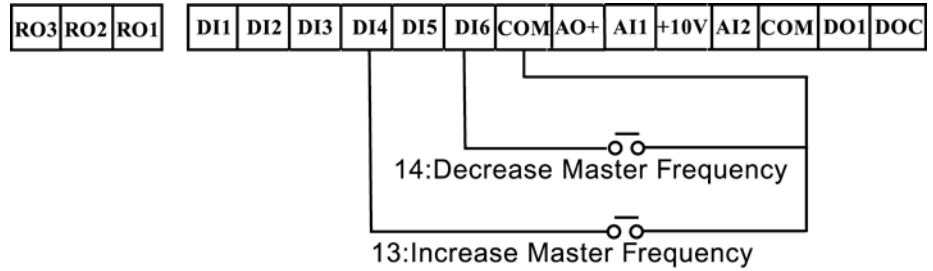

Setting 15

A digital input may be used to select direction.

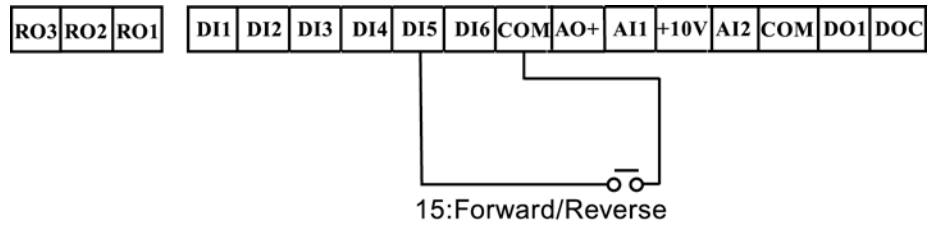

Setting 16

A digital input terminal may be used to disable users from changing the parameters.

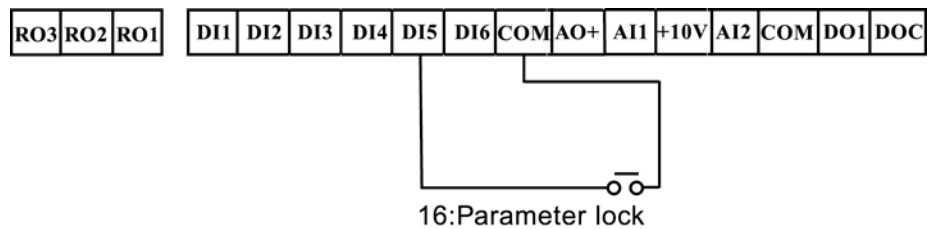

Setting 17

A digital input terminal may be used for acceleration/deceleration inhibit. When the command is received, acceleration and deceleration is stopped and the AC drive maintains a constant speed. See diagram below.

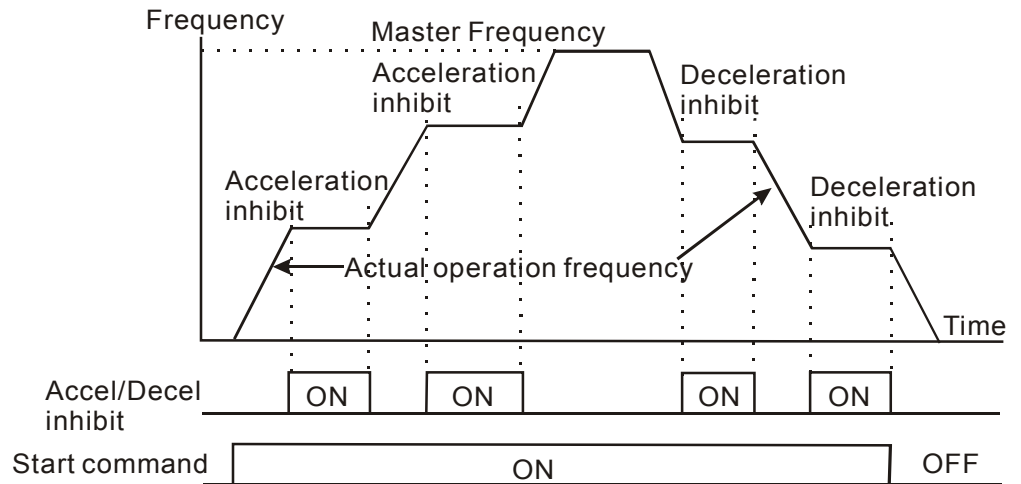
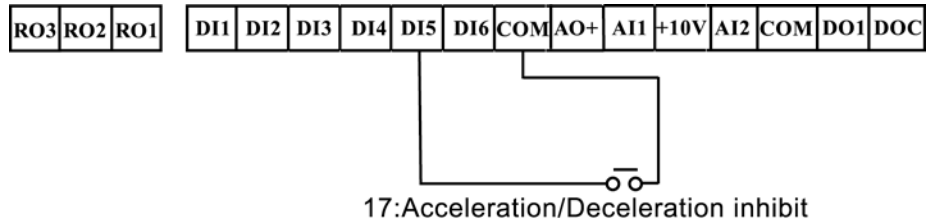

Setting 18

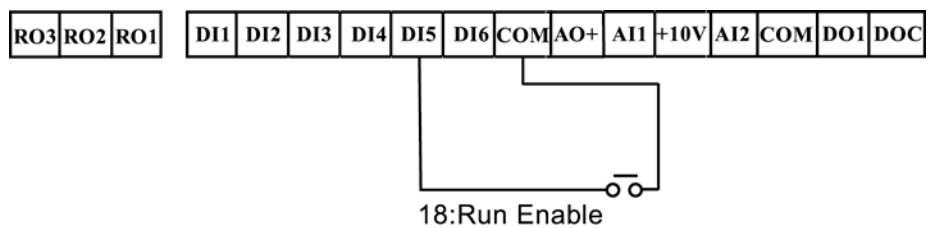

Settings 19, 20

Setting 19 allows an input terminal to generate an “External Pause”. When the External Pause signal is received, the AC drive will stop all output and the motor will coast to a stop. When the External Pause control is removed, the AC drive will start its speed search function, synchronize with the motor speed, and then accelerate to Master frequency.

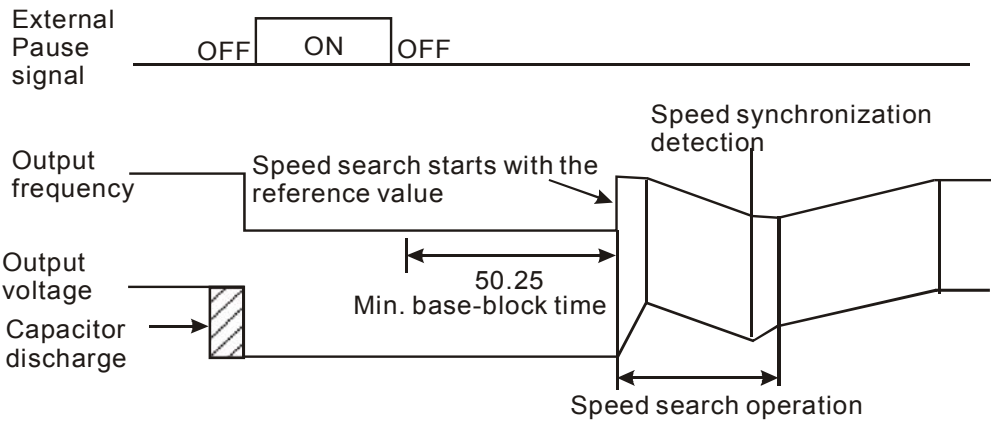
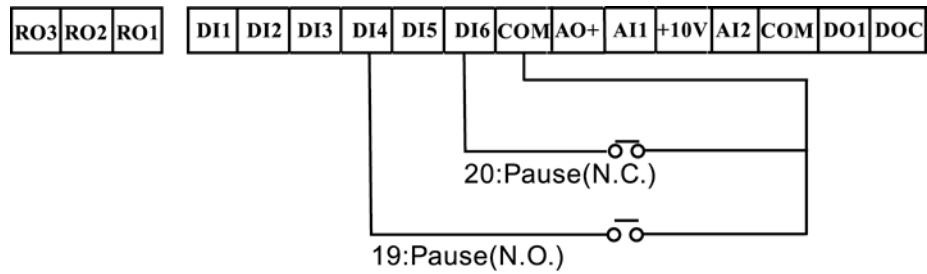

Setting 21

Allows an input terminal to disable PID operation as shown below.

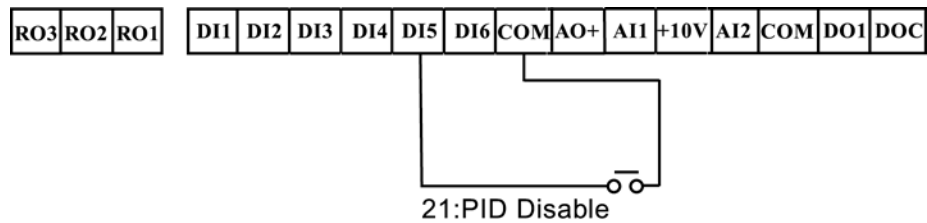

Settings 22, 23

A setting of 22, allows an input terminal to enable the AC drives internal PLC program and a setting of 23, allows an input terminal to pause the PLC program.

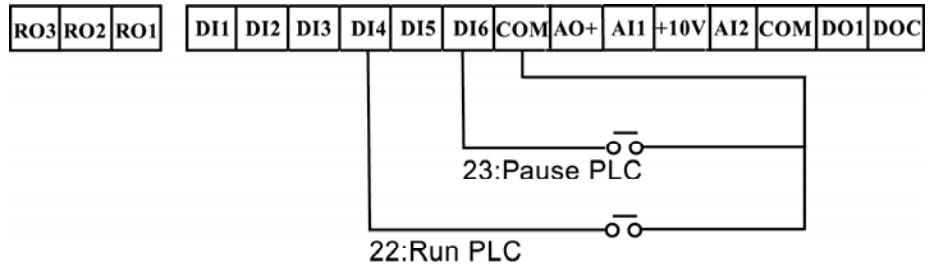

Settings 24

A digital input terminal may be used to increase the AC drive's internal counter. When an input is received, the counter is increased by 1. The counter input may be connected to an external Pulse Signal Generator to count a process or unit of material. See the diagram below.

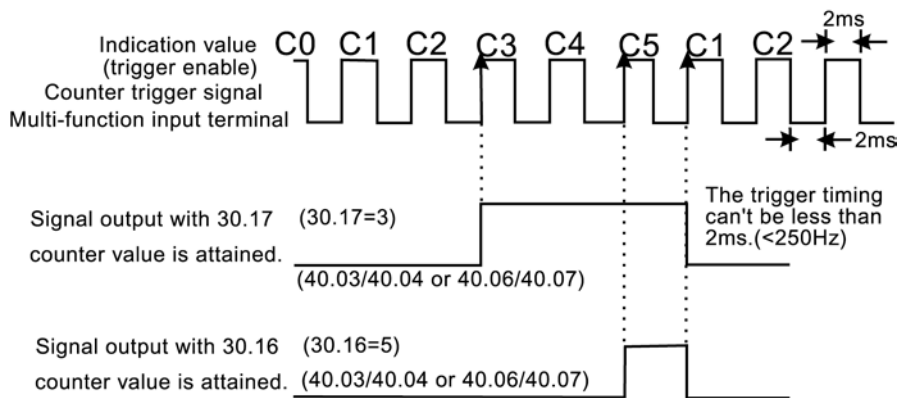
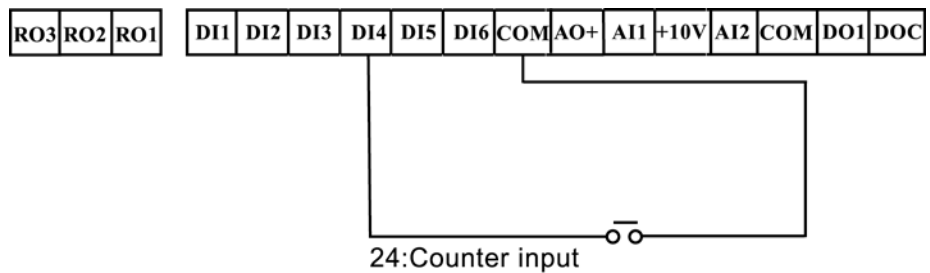

Settings 25

A digital input terminal may be used to reset the counter as shown below.

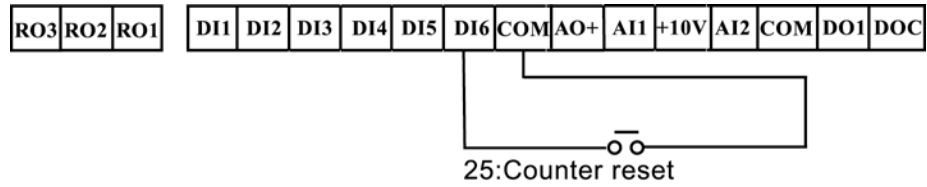

Settings 26

A digital input terminal may be used to select the first or second Source of Master Frequency as shown below.

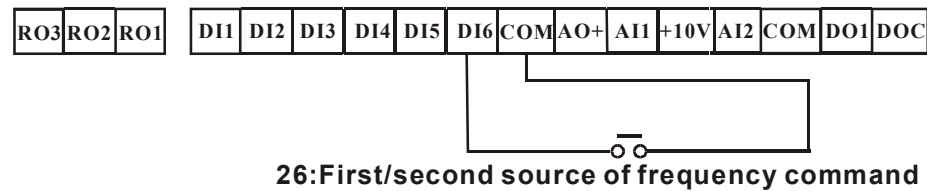

30.16

Final Count Value

Range: 00 to 9999

Default: 00

This parameter defines the final count value for the MVX9000 internal counter. The counter is incremented by a low-to-high transition on a Digital Input Terminal: DI3 to DI6.

A selected Digital/Relay Output Terminal may be programmed to activate upon completion of the final count.

30.17

Intermediate Count Value

Range: 00 to 9999

Default: 00

This parameter sets the intermediate count value for the MVX9000 internal counter. The counter is incremented by a low-to-high transition on a Digital Input Terminal: DI3 to DI6. The count will start at c01.

A selected Digital/Relay Output Terminal may be programmed to activate upon completion of the intermediate count.

30.18

Preset Speed 1

Range: 0.0 to 400.0 Hz

Default: 0.0 Hz

Unit: 0.1 Hz

30.19

Preset Speed 2

Range: 0.0 to 400.0 Hz

Default: 0.0 Hz

Unit: 0.1 Hz

30.20
Preset Speed 3 Range: 0.0 to 400.0 Hz Default: 0.0 Hz
 Unit: 0.1 Hz

30.21
Preset Speed 4 Range: 0.0 to 400.0 Hz Default: 0.0 Hz
 Unit: 0.1 Hz

30.22
Preset Speed 5 Range: 0.0 to 400.0 Hz Default: 0.0 Hz
 Unit: 0.1 Hz

30.23
Preset Speed 6 Range: 0.0 to 400.0 Hz Default: 0.0 Hz
 Unit: 0.1 Hz

30.24
Preset Speed 7 Range: 0.0 to 400.0 Hz Default: 0.0 Hz
 Unit: 0.1 Hz

These parameters may be set during operation.

The Digital Input Terminals (refer to 30.11 to 30.15) are used to select one of the MVX9000 Preset Speeds. The speeds (frequencies) are determined by 30.18 to 30.24.

Preset Speeds 30.18 to 30.24 in conjunction with 50.46 to 50.52 provide the process logic control (PLC) function.

30.25
Display Frequency (Hz) Range: Default: 00
or Percent (%) 00 Frequency (hz)
 01 Percent (%)

This parameter allows the display to reference Frequency or Percentage.

30.26
Digital Extension Input Range: See Parameter 30.12 Default: 00
D17

30.27
Digital Extension Input Range: See Parameter 30.12 Default: 00
D18

Available settings are the same as 30.12 to 30.15

These parameters select the function of the optional extension I/O. These parameters are not visible on the MVX9000 until the extension I/O is installed.

Group 40 — Outputs

40.01

Analog Output Signal

- Range: _____ Default: 00
- 00 Output Frequency (0 to Maximum Output Frequency)
 - 01 Output Current (0 to 250% of the rated AC drive current)
 - 02 PID Feedback Signal (0 to maximum feedback)
 - 03 Output Power (0 to 100% of the rated AC drive power)

This parameter selects the reference value for the 0-10V analog output (AO+ to COM).

40.02

Analog Output Gain

- Range: 0 to 200% _____ Default: 100
- Unit: 1%

This parameter may be set during operation.

The parameter sets the voltage range for analog output terminals AO+ to COM.

The analog output voltage is directly proportional to the selection made in 40.01.

If setting 00 is chosen, the analog output voltage on AO+ to COM is directly proportional to the output frequency of the AC drive. With 40.02 set at 100%, the Maximum Output Frequency of the AC drive corresponds to +10VDC on AO.

If setting 01 is chosen, the analog output voltage is directly proportional to the output current of the AC drive. With 40.02 set to 100%, +10 VDC corresponds to 250% of AC drive rated current.

Note: Any type of voltmeter may be used. If the meter reads full scale at a voltage less than 10 volts, then 40.02 should be set by the following formula:

$$40.02 = ((\text{meters full scale voltage})/10) \times 100\%$$

For Example: When using the meter with full scale of 5 volts, adjust 40.02 to 50%

40.03

**Digital Output Terminal
D01**

Range: 00 to 20

Default: 02

40.04

**Relay Output Terminal
RO1, RO2, RO3**

Range: 00 to 20

Default: 03

- 00 Not Used
- 01 Ready
- 02 Inverter Running
- 03 Inverter Fault
- 04 Warning (See warning codes in Chapter 7)
- 05 At speed
- 06 Zero Speed
- 07 Above desired frequency (40.05)
- 08 Below desired frequency (40.05)
- 09 PID supervision
- 10 Over voltage supervision
- 11 Over heat supervision
- 12 Over current stall supervision
- 13 Over voltage stall supervision
- 14 Low voltage indication
- 15 PLC program running
- 16 PLC program step complete
- 17 PLC program completion
- 18 PLC program pause
- 19 Terminal count value attained
- 20 Preliminary count value attained
- 21 Reverse direction notification
- 22 Under current detection

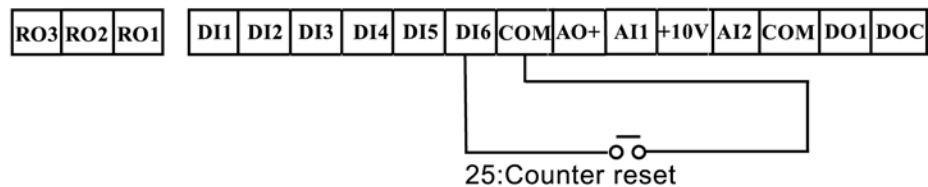
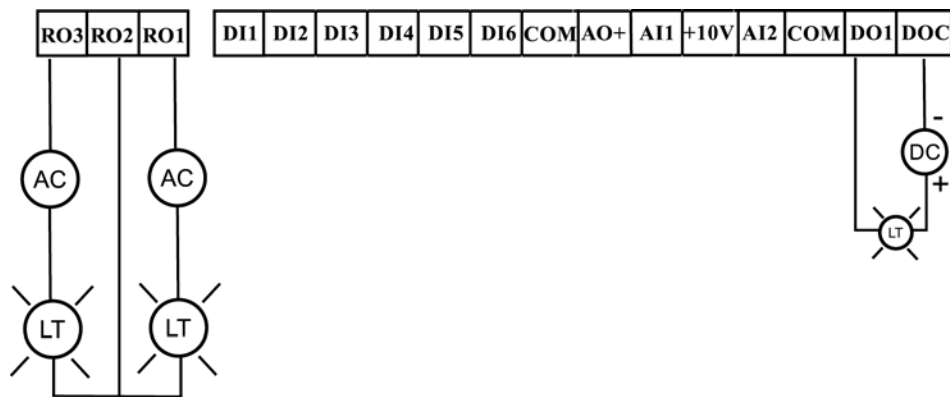

Function Explanations:

- 00 Not Used: all unused output terminals of the AC drive should be set to 00.
- 01 Ready: The output terminal will be active when the drive has no faults and is ready to run.
- 02 Inverter Running: The output terminal will be active when the drive is generating an output from the T1, T2, T3 terminals.
- 03 Inverter Fault: The output terminal will be activated when faults occur (oc, ov, oH, oL, oL1, EF, cF3, HPF, ocA, ocd, ocn, GF).
- 04 Warning: The output terminal will be active when there is a fault with communication or PID feedback.
- 05 At Speed: The output terminal will be active when the drive output frequency reaches the value set by your command source.
- 06 Zero Speed: The output terminal will be active when the drives U, V, W terminals are generating no output.
- 07 Above Desired Frequency: The output terminal will be active when the output frequency is above the desired frequency (40.05).
- 08 Below Desired Frequency: The output terminal will be active when the output frequency is below the desired frequency (40.05).
- 09 PID supervision
- 10 Over Voltage Warning: The output terminal will be active when output voltage of the drive exceeds 90% of the maximum voltage limit.
- 11 Over Heat Warning: The output terminal will be active when temperature of the drive exceeds 90% of the maximum heat limit.
- 12 Over Current Stall Warning: The output terminal is active when the Over current stall function is enabled.
- 13 Over Voltage Stall Warning: The output terminal will be active when the over voltage stall function is enabled.
- 14 Low Voltage: The output will be active when the input voltage drops below the minimum voltage limit.
- 15 PLC Program running: The output terminal will be active when the PLC function is running.
- 16 PLC Program Step complete: The output terminal will be active when each PLC step is completed.
- 17 PLC Program Completed: The output terminal will be active when the PLC function has completed and stopped.
- 18 PLC Program Pause: The output terminal will be active when the PLC function has been paused.
- 19 Final count value attained: The output terminal will be active when the count reaches the setting in 30.16.
- 20 Intermediate count value attained: The output terminal will be active when the count reaches the setting in 30.17.
- 21 Reverse direction notification: The output terminal will be active when the drive is in reverse.
- 22 Under current detection: The output terminal will be active when the output current is under Pr. 70.11 and the time has exceeded Pr. 70.13.

40.05
Desired Frequency Attained Range: 0.0 to 400.0 Hz Default: 0.0
 Unit: 0.1Hz

If a Digital/Relay output terminal is set to function as Desired Frequency, then the output will be activated when the programmed frequency is attained.

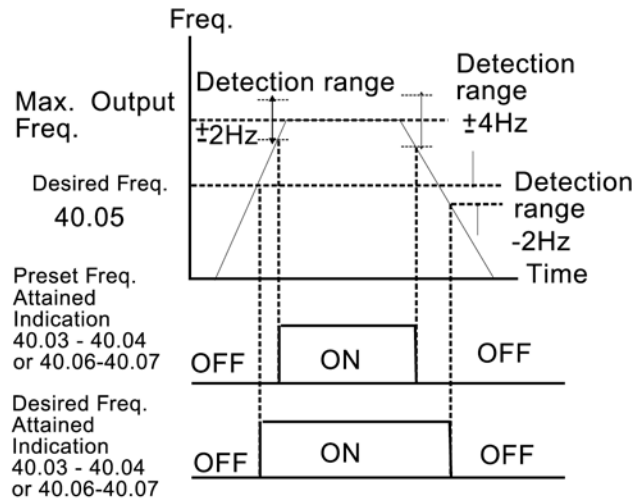

Desired Freq. Attained & Preset Freq. Attained

40.06
Relay Extension Output RO4, RO5, RO6 Range: See Parameter 40.03 Default: 00

40.07
Relay Extension Output RO7, RO8, RO9 Range: See Parameter 40.03 Default: 00

Available settings are the same as 40.03 to 40.04.

These parameters select the function of the optional extension I/O. These parameters are not visible on the MVX9000 until the extension I/O is installed.

Group 50 — AC Drive Control

**50.01
Source of Master
Frequency**

- Range: Default: 01
- 00 Master Frequency determined by digital keypad on the drive.
 - 01 Master Frequency determined by keypad potentiometer.
 - 02 Master Frequency determined by 0-10V on terminal AI1
 - 03 Master frequency determined by 4-20mA on terminal AI2
 - 04 Master frequency determined by RS485

**50.02
Source of Operation
Command**

- Range: Default: 00
- 00 Operating commands determined by the Digital Keypad.
 - 01 Operating commands determined by the External Control Terminals. Keypad STOP key is enabled.
 - 02 Operating commands determined by the External Control Terminals. Keypad STOP key is not enabled.
 - 03 Operating commands determined by the RS-485 communication interface. Keypad STOP key is enabled.
 - 04 Operating commands determined by the RS-485 communication interface. Keypad STOP key is not enabled.

**50.03
Stop Method**

- Range: Default: 00
- 00 Ramp to stop
 - 01 Coast to stop

This parameter determines how the motor is stopped when the AC drive receives a valid stop command.

Ramp: The AC drive decelerates the motor to the Minimum Output Frequency based on the time set in Pr. 50.12.

Coast: The AC drive stops the output instantly upon command, and the motor free spins until it comes to a complete stop.

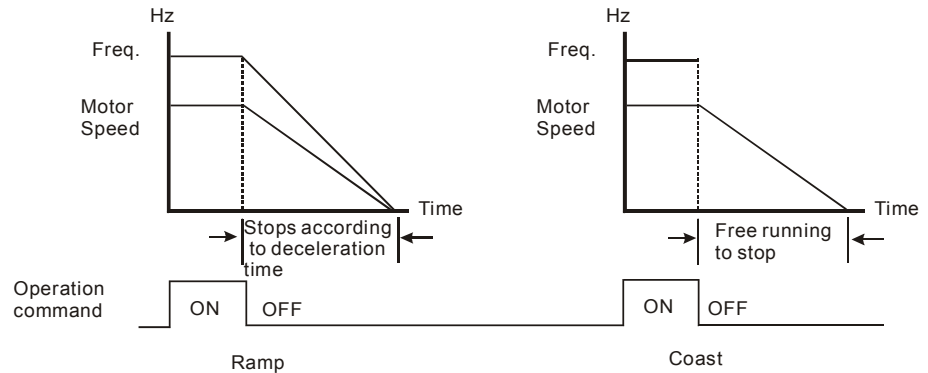

50.04
Maximum Output
Frequency

Range: 50.0 to 400.0 Hz Default: 60
 Unit: 0.1Hz

This parameter determines the AC drive's Maximum Output Frequency. All the AC drive accelerations and decelerations are scaled to correspond to this maximum output frequency.

50.05
Motor Nameplate
Frequency

Range: 10.0 to 400.0Hz Default: 60
 Unit: 0.1Hz

This value should be set according to the rated frequency of the motor as indicated on the motor nameplate. Motor Nameplate Frequency determines the volts/hertz ratio.

For example: if the drive is rated for 460 VAC output and the Motor Nameplate Frequency is set to 60Hz, the drive will maintain a constant ratio of 7.66 v/Hz. **The setting value must equal to or greater than the Mid-Point Frequency (50.07).**

50.06
Motor Nameplate Voltage

Range: 230V series 0.1 to 255.0V Default: 230.0
 Range: 460V series 0.1 to 510.0V Default: 460.0

This parameter determines the motor nameplate voltage of the AC drive. The motor nameplate voltage setting must be smaller than or equal to the rated voltage of the motor as indicated on the motor nameplate. **The setting value must equal to or greater than the Mid-Point Voltage (50.08).**

50.07
Mid-Point Output
Frequency

Range: 0.1 to 400.0Hz Default: 1.5
 Unit: 0.1Hz

The parameter sets the Mid-Point Frequency of V/F curve. With this setting, the V/F ratio between Minimum Frequency and Mid-Point frequency can be determined. **This parameter must be equal to or greater than Minimum Output Frequency (50.09) and equal to or less than Motor Nameplate Frequency (50.05).**

During Sensorless Vector this parameter is disabled.

50.08

Mid-Point Output Voltage

Range: 230V series 0.1 to 255V Default: 10.0

Range: 460V series 0.1 to 510V Default: 20.0

The parameter sets the Mid-Point Voltage of any V/F curve. With this setting, the V/F ratio between Minimum Frequency and Mid-Point Frequency can be determined. ***This parameter must be equal to or greater than Minimum Output Voltage (50.10) and equal to or less than Motor Nameplate Voltage (50.06).***

During Sensorless Vector this parameter is disabled.

50.09

Minimum Output Frequency

Range: 0.1 to 20.0Hz Default: 1.5

Unit: 0.1Hz

This parameter sets the Minimum Output Frequency of the AC drive V/F curve. This parameter must be equal to or less than the Mid-Point Output Frequency (50.07).

50.10

Minimum Output Voltage

Range: 230V series 0.1 to 50V Default: 10.0

Range: 460V series 0.1 to 100V Default: 20.0

This parameter sets the Minimum Output Voltage of the AC drive V/F curve. This parameter must be equal to or less than Mid-Point Output Voltage (50.08).

During Sensorless Vector this parameter is disabled.

Below are three examples of how a V/F curve may change due to the setting of parameters 50.04 to 50.10.

50.11

Sensorless Vector Enable

Range: Default: 00

00: Disabled

01: Enabled

This parameter enables the Sensorless Vector function. When the drive is set for Sensorless Vector the starting torque will be 150% at 1hz. Also the Mid-Point Output Frequency, Mid-Point Output Voltage, and Minimum Output Voltage are disabled. For the best results, please conduct the following.

1. Set the correct motor nameplate voltage and Base Frequency
2. Conduct an Auto tune. (See parameter 60.03)
3. Set the Minimum output Frequency (50.09) to 0.1Hz

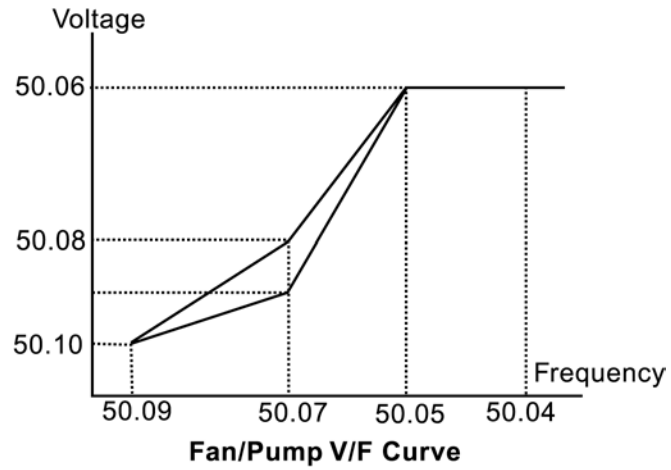
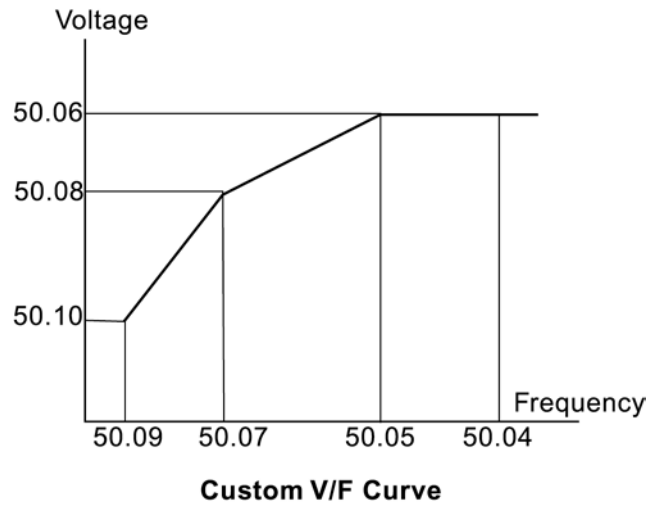
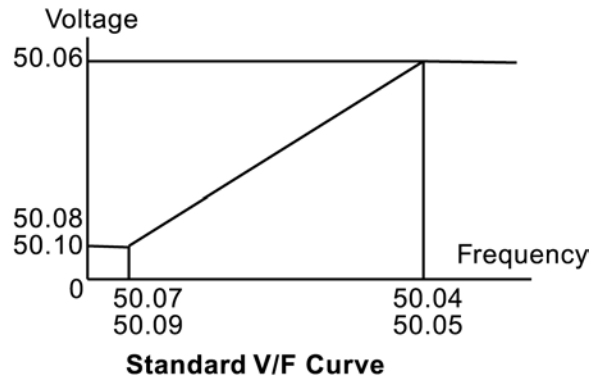

50.12
Acceleration Time 1 Range: 0.01 to 600.00 seconds Default: 10s
 Unit: 0.01 seconds

50.13
Deceleration Time 1 Range: 0.01 to 600.00 seconds Default: 10s
 Unit: 0.01 seconds

50.14
Acceleration Time 2 Range: 0.01 to 600.00 seconds Default: 10s
 Unit: 0.01 seconds

50.15
Deceleration Time 2 Range: 0.01 to 600.00 seconds Default: 10s
 Unit: 0.01 seconds

These parameters may be set during operation.

50.12: This parameter sets the time required for the AC drive to ramp from 0 Hz to its Maximum Output Frequency (50.04). The rate is linear unless S-Curve is “Enabled.”

50.13: This parameter sets the time required for the AC drive to decelerate from the Maximum Output Frequency (50.04) down to 0 Hz. The rate is linear unless S-Curve is “Enabled.”

The second acceleration and deceleration times (50.14 and 50.15) are identical to the standard acceleration and deceleration times (50.12 and 50.13). The second acceleration and deceleration times are used only when a Digital input terminal is programmed to select between times 1 and 2 (Refer to 30.12 to 30.15) or when a frequency other than 0 is set in parameters 50.16 and 50.17.

In the diagram shown below, the acceleration and deceleration times of the AC drive are between 0 Hz and Maximum Output Frequency (50.04). If the Maximum Output Frequency is 60 Hz, Minimum Output Frequency (50.09) is 1.0Hz, and acceleration and deceleration times are set to 10 seconds. The actual time for the AC drive to accelerate from start-up to 60 Hz is 9.83 seconds and the deceleration time is also 9.83 seconds. Remember the drive always starts timing from 0Hz.

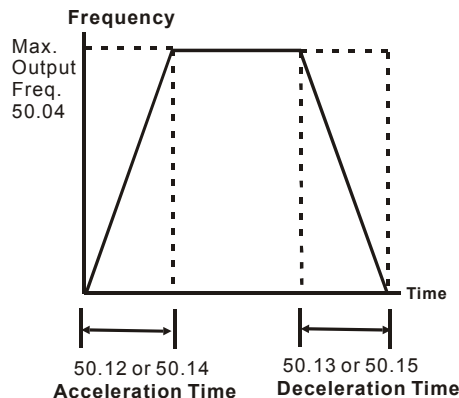

50.16
Transition Point for Acceleration Time 1 to 2 Range: Default: 0.0
 0.0 Disabled
 0.1 to 400hz Enabled

50.17
Transition Point for Deceleration Time 1 to 2 Range: Default: 0.0
 0.0 Disabled
 0.1 to 400Hz Enabled

50.18
Acceleration S-Curve Range: Default: 00
 00 Disabled
 01 to 07 Enabled

50.19
Deceleration S-Curve Range: See Parameter 50.18 Default: 00

The above two parameters are used to smooth out the transition between the acceleration/deceleration and steady state speed. The S-Curve is enabled with settings of 1 to 7, with the highest number generating the smoothest transition.

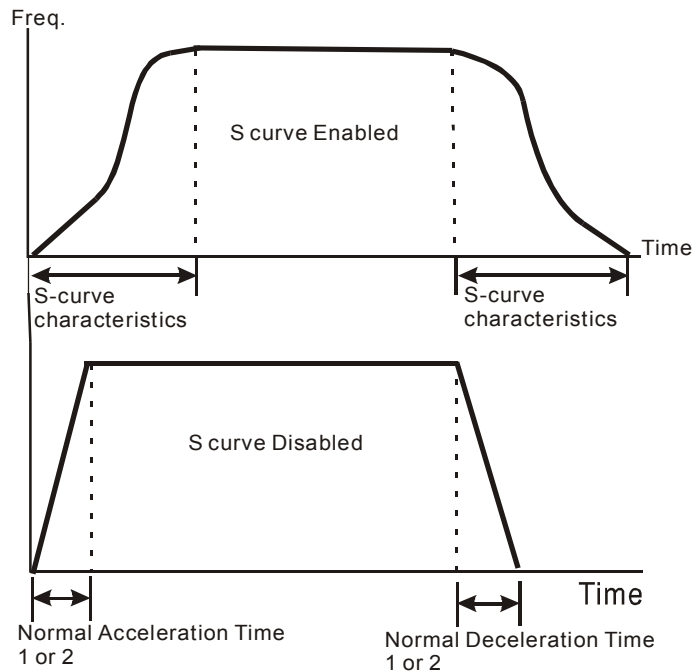

50.20
Jog Acceleration / Deceleration Time Range: 0.01 to 600.00 seconds Default: 1.00 sec
 Unit: 0.01 seconds

This parameter sets the acceleration and deceleration time for the Jog operation.

50.21
Jog Frequency Range: 0.1 to 400.0 Hz Default: 6.0 Hz
 Unit: 0.1 Hz

This parameter may be set during operation.

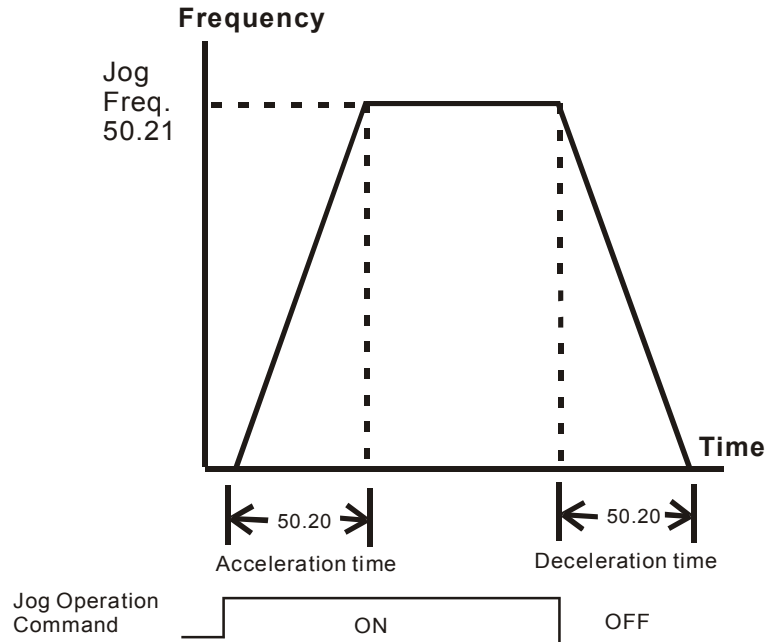

50.22
Reverse Operation Enable Range: 00 enable REV operation Default: 00
 01 disable REV operation

This parameter enables the AC Motor Drive's ability to operate in the reverse direction.

50.23
Momentary Power Loss
and Flying Start
Operation

Range:	Default: 00
00	Operation stops after momentary power loss
01	Operation continues after momentary power loss and flying start search starts with the Master Frequency reference value
02	Operation continues after momentary power loss and flying start search starts with the minimum frequency

50.24
Maximum Allowable
Power Loss Time (Ride
Through)

Range: 0.3 to 5.0 seconds	Default: 2.0 sec
Unit: 0.1seconds	

During a power loss, if the power loss time is less than the time defined by this parameter, the AC drive will resume operation. If the Maximum Allowable Power Loss Time is exceeded, the AC drive output is then turned off.

If the power loss occurs while the AC drive is under heavy load, it is possible that all available ride through power will be dissipated in the motor and the AC drive will shut down quickly (less than 1 second).

50.25
Pause Time after
Momentary Power loss
(delay before restart)

Range: 0.3 to 10 seconds	Default: 0.5 sec
Unit: 0.1 seconds	

When a momentary power loss is detected, the AC drive waits for a specified time interval determined by 50.25 before resuming operation. This time interval should be set to a value where the residual output voltage due to regeneration is nearly zero, before the drive resumes operation.

This parameter also determines the wait time after performing an external PAUSE and Fault Reset function.

50.26
Maximum Speed Search
Current Level

Range: 30 to 200%
 Unit: 1%

Default: 150%

Following a momentary power failure, the AC drive will start its speed search operation, only if the output current is greater than the value determined by 50.26. When the output current is less than that of 50.26, the AC drive output frequency is at a “speed synchronization point”. The drive will begin to accelerate or decelerate the motor back to the operating frequency at which it was running prior to the power failure.

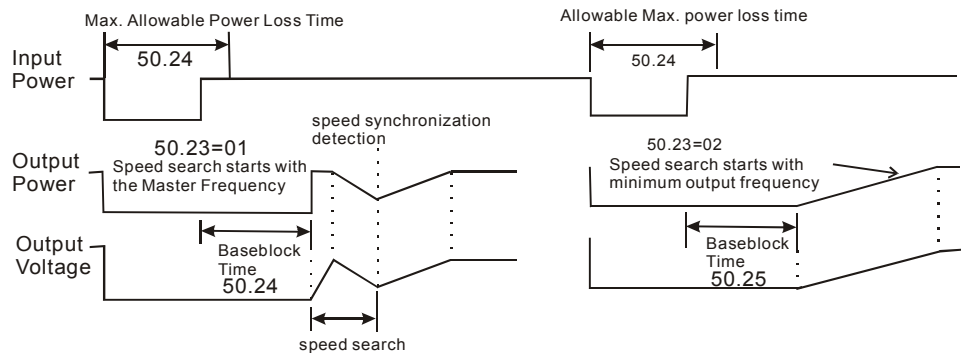

50.27
Upper Limit of Output
Frequency

Range: 0.1Hz to 400.0Hz
 Unit: 0.1Hz

Default: 400.0 Hz

This parameter must be equal to or greater than the Lower Limit of Output Frequency 50.28.

50.28
Lower Limit of Output
Frequency

Range: 0.0Hz to 400.0Hz
 Unit: 0.1Hz

Default: 0.0 Hz

The Upper and Lower Limit parameters are to prevent operation at frequencies where machine damage may occur.

If the Upper Limit of Output Frequency is set at 50Hz and the Maximum Output Frequency is set at 60Hz, the actual Maximum Output Frequency will be limited to 50Hz.

If the Lower limit of Output Frequency is set at 10Hz, and the Minimum Output Frequency is set at 1.0Hz, then any Command Frequency between 1-10Hz will generate a 10Hz output from the drive.

This parameter must be equal to or less than the Upper Limit of Output Frequency 50.27.

50.29
Skip Frequency 1 Range: 0.0 to 400.0 Hz Default: 0.0
 Unit: 0.1 Hz

50.30
Skip Frequency 2 Range: 0.0 to 400.0 Hz Default: 0.0
 Unit: 0.1 Hz

50.31
Skip Frequency 3 Range: 0.0 to 400.0 Hz Default: 0.0
 Unit: 0.1 Hz

These three parameters determine the three Skip Frequencies that, in conjunction with 50.32, Skip Frequency Bandwidth, will cause the AC motor drive to skip operation at each frequency band.

50.32
Skip Frequency Bandwidth Range: 0.0 to 20.0 Hz Default: 0.0
 Unit: 0.1 Hz

This parameter determines the frequency band for a given Skip Frequency. Half of the Skip Frequency Band is above the Skip Frequency and the other half is below. Programming this parameter to 0.0 disables all skip frequencies.

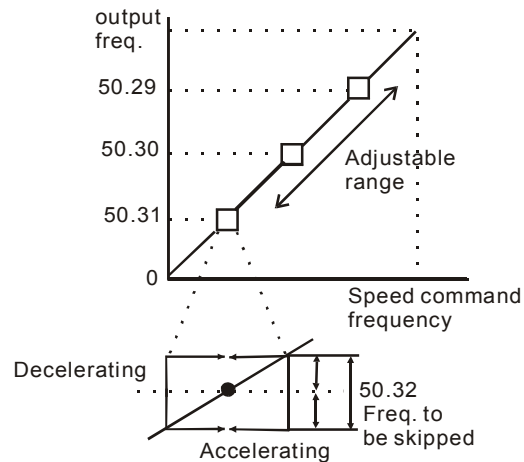

50.33
Auto Restart After Fault Range: 00 to 10 Default: 00
 Number of times to restart

After a fault occurs (allowable faults: over-current OC, over-voltage OV), the AC drive can be reset/restarted automatically up to 10 times. Setting this parameter to 0 will disable the reset/restart operation after any fault has occurred. When enabled, the AC drive will restart using the speed search function, which starts at the Master Frequency reference value. To set the fault recovery time after a fault, please see 50.25, Pause Time.

50.34
PID Set-Point Location Range: Default: 00
00 Disable
01 Keypad (based on setting of 20.03)
02 AI1 (external 0-10V)
03 AI2 (external 4-20mA)
04 Parameter 50.43 (non-variable set point)

50.35
Feedback Signal Selection Range: Default: 00
00 Positive Feedback AI1 (0-10V)
01 Negative Feedback AI1 (0-10V)
02 Positive Feedback AI2 (4-20mA)
03 Negative Feedback AI2 (4-20mA)
This parameter selects the PID analog feedback type.

50.36
P (Gain) adjustment Range: 0.0 to 10.0 Default: 1.0

50.37
I (Integration) adjustment Range: 0.0 to 100.0 seconds Default: 1.0sec
Units: 0.1seconds
When parameter is set to 0.0 the function is disabled.

50.38
D (Derivative) adjustment Range: 0.0 to 1.0 sec Default: 0.0sec
Units: 0.1 seconds
When parameter is set to 0.0 the function is disabled.

50.39
Upper Limit of Integral Control Range: 00 to 100% Default: 100%

50.40
PID Output Delay Filter Time Range: 0.0 to 2.5 seconds Default: 0.0sec
Units: 0.1seconds

50.41

4 - 20mA Input Loss Detection Time Range: 0.1 to 3600 seconds
00 Disabled

Default: 60sec

Units: 0.1second

If the 4-20mA input falls below 4mA, the drive will consider this a loss of input speed command. Upon loss of 4-20mA, the AC drive will begin to record time. If the time set in 50.41 is reached, the AC drive will follow the operation selection in 50.42.

50.42

4 – 20mA Input Loss Operation Range: Default: 00
00 Warn and Stop operation

01 Warn and continue to run at last known speed command

This parameter selects the operation of the AC drive after a loss of 4-20mA input is detected and the time set in 50.41 is reached. This parameter is disabled if 30.04 is set to 0.0mA.

50.43

PID Set-Point Range: Default: 00hz
0.1 to 400.0hz
00hz Disabled

Units: 0.1hz

This parameter sets the frequency target value for the PID function.

50.44

PLC Operation Mode Range: Default: 00
00 Disable PLC operation

01 Execute one program cycle

02 Continuously execute program cycles

03 Execute one program cycle step by step

04 Continuously execute program cycles step by step

This parameter selects the function of the PLC operation. The PLC program may be used in lieu of any External Controls, Relays or Switches. The AC drive will change speeds and directions according to the user's programming.

Example 1

50.44 = 1: Execute one cycle of the PLC program.

30.18 to 30.24: Frequency of 1st to 7th step speeds.

30.12 to 30.15: Digital Input Terminals (set one to 22).

40.03 to 40.04: Digital/Relay Output Terminals (may be set to 15 through 18).

50.45: Direction of operation for 1st to 7th step speed.

50.46 to 50.52: Operation time of 1st to 7th step speeds.

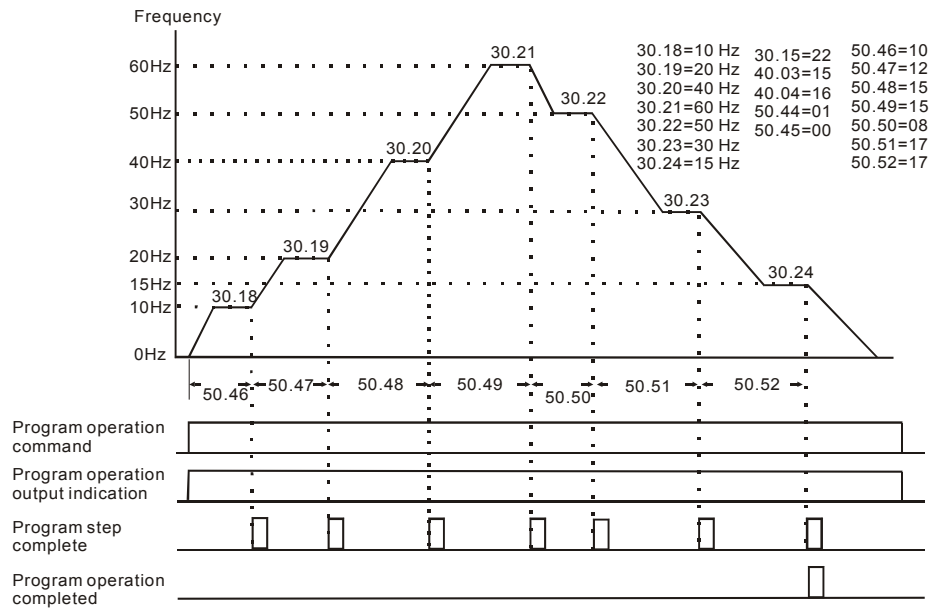

Example 2 (50.44 = 01) Execute one cycle through the PLC program:

In this example, the PLC program runs continuously. It should be noted that the times of reverse motion may be shorter than expected, due to the acceleration/deceleration time.

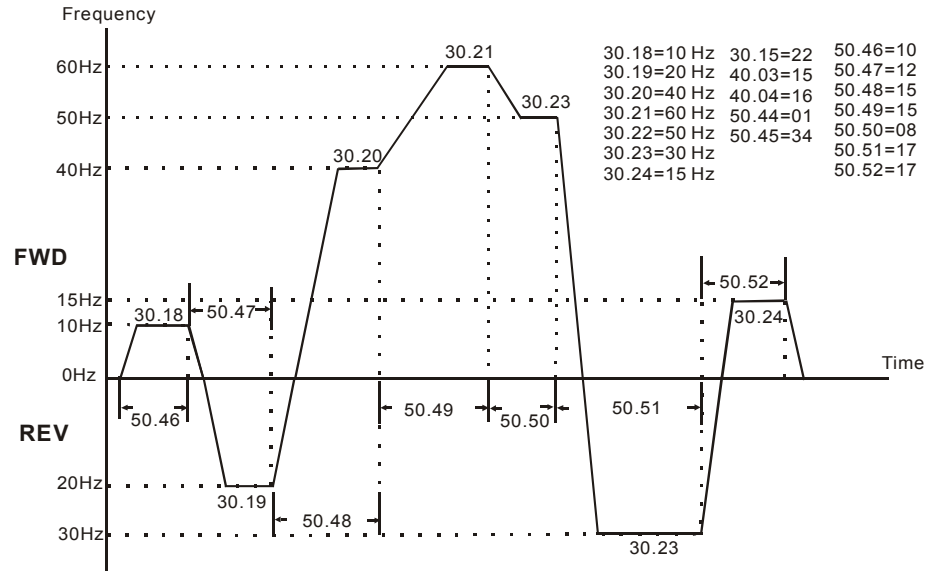

Application Note:

Changing the value of Jog parameters 50.20 and 50.21 will interrupt PLC program execution. PLC program execution will not be interrupted when other parameter values are changed.

50.45
PLC Forward/Reverse Motion

Range: 0 to 127

Default: 0

This parameter controls the direction of motion for the multi-speeds 30.18 to 30.24 during the PLC function.

To generate the setting for this parameter the following equation must be solved.

$$= (\text{direction of speed 7} \times \text{value of bit 7}) + (\text{direction of speed 6} \times \text{value of bit 6}) + (\text{direction of speed 5} \times \text{value of bit 5}) + (\text{direction of speed 4} \times \text{value of bit 4}) + (\text{direction of speed 3} \times \text{value of bit 3}) + (\text{direction of speed 2} \times \text{value of bit 2}) + (\text{direction of speed 1} \times \text{value of bit 1})$$

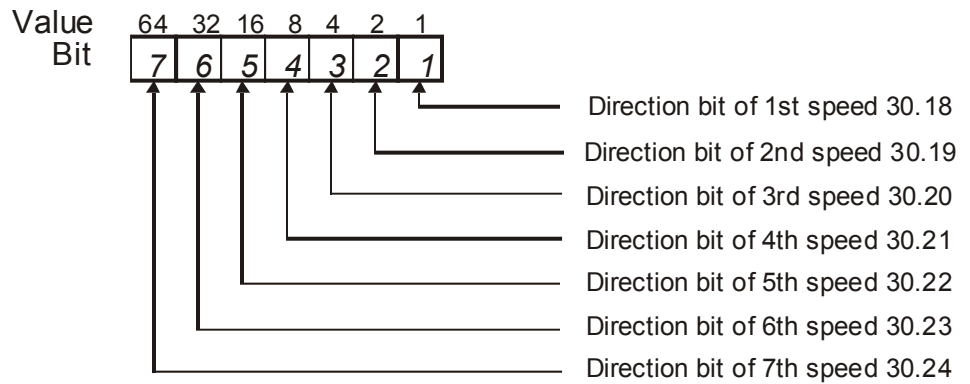

Direction of Speed values:

Forward = 0

Reverse = 1

Example:

In this example, the Preset Speeds 6 and 2 are to go in reverse direction and all others are to move in a forward direction.

As shown in the table above, each bit has an associated value.

Bit 7 = 64, Bit 6 = 32, Bit 5 = 16, Bit 4 = 8

Bit 3 = 4, Bit 2 = 2 and Bit 1 = 1

Then each direction has a number associated with it as stated below.

Use the number 0 for a Forward direction.

Use the number 1 for a Reverse direction.

With the above information the equation can be solved.

$$= (0 \times 64) + (1 \times 32) + (0 \times 16) + (0 \times 8) + (0 \times 4) + (1 \times 2) + (0 \times 1)$$

$$= 0 + 32 + 0 + 0 + 0 + 2 + 0$$

50.45 = 34 for this example

50.46 Time Duration of 1st Preset Speed	Range: 0 to 9999 Unit: 1 sec	Default: 0
50.47 Time Duration of 2nd Preset Speed	Range: 0 to 9999 Unit: 1 sec	Default: 0
50.48 Time Duration of 3rd Preset Speed	Range: 0 to 9999 Unit: 1 sec	Default: 0
50.49 Time Duration of 4th Preset Speed	Range: 0 to 9999 Unit: 1 sec	Default: 0
50.50 Time Duration of 5th Preset Speed	Range: 0 to 9999 Unit: 1 sec	Default: 0
50.51 Time Duration of 6th Preset Speed	Range: 0 to 9999 Unit: 1 sec	Default: 0
50.52 Time Duration of 7th Preset Speed	Range: 0 to 9999 Unit: 1 sec	Default: 0

50.46 to 50.51 set the operation time of each Preset Speed during the PLC operation mode.

The maximum value of these parameters is 9999 seconds and is displayed as 9999.

Note: *If a time is set to "0" (0 Sec), the corresponding speed will be skipped. This is used to reduce the number of program steps.*

50.53 Auto Acceleration Deceleration	Range:	Default: 00
	00	Linear acceleration and deceleration
	01	Auto acceleration and linear deceleration
	02	Linear acceleration and auto deceleration
	03	Auto acceleration and deceleration
	04	Auto acceleration and deceleration, but limited by 50.12 to 50.15

Linear acceleration and deceleration times are based on 50.12 to 50.15

If this parameter is set to 03, the AC drive will accelerate and decelerate in the fastest and smoothest means possible by automatically adjusting the time of acceleration and deceleration.

If the application has a high duty cycle of starts and stops or the load changes often, it is recommended to use linear Acceleration and Deceleration for stability.

50.54
Sleep Frequency Range: Default: 0.0
 0.0 Disabled
 0.1 to 400hz Enabled

The Master Frequency point where the AC drive begins to “Sleep” and stop its output. Note: The sleep frequency must be smaller than or equal to the wake frequency.

50.55
Wake Frequency Range: Default: 0.0
 0.0 to 400hz

The Master Frequency point where the drive begins to output again.

50.56
Sleep Time Delay Range: Default: 1.0
 0.0 to 600 sec.

The time delay before going into a sleep mode.

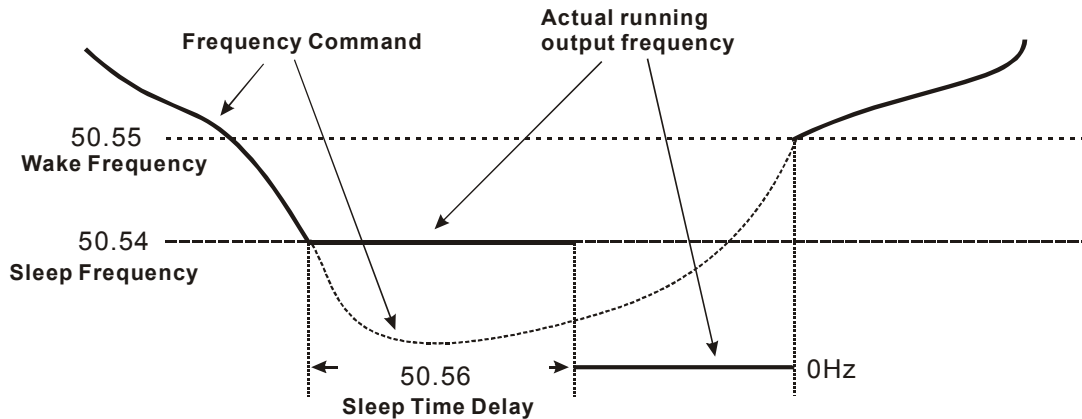

50.57
Second Source of Master Frequency Range: Default: 00
 00 Second Master Frequency by digital keypad up/down
 01 Second Master Frequency by keypad potentiometer
 02 Second Master Frequency by 0 to +10V input on AI1
 03 Second Master Frequency by 4 to 20mA input on AI2
 04 Second Master Frequency by RS-485

This parameter determines the Second Source of Master Frequency when a digital input switch is used.

Group 60 — Motor Control

60.01

Motor Rated Current Default: xx.x A

Enter the motor's nameplate rated amps.

The value must be between 30 to 120% of the drive's rated output current. This parameter sets the drive's output current limit.

This parameter may be set during operation.

60.02

Motor No-Load Current Default: xx.x A

Enter the motor's no load current in Amps. If the motor no load amps are not known, leave this parameter at factory default.

The value must be between 0 to 99% of the drive's rated output current and also less than parameter 60.01.

60.02 has a great effect on how accurate the slip compensation function works. An incorrect setting will cause poor slip compensation.

This parameter may be set during operation.

60.03

Motor Auto Tuning Range: Default: 00
00 Disabled
01 DC test only
02 DC test and no load current test

To conduct the auto tuning feature, select 01 or 02 and then press "Start". If the motor is loaded, it is recommended to select 01.

60.04

Motor's Stator Resistance Range: 00 to 65535 m Ohms Default: 00
Units: milli-ohms

This parameter determines the motor's line-to-line resistance. The value may be entered manually or via the Auto Tune feature 60.03. This value should be entered when using Sensorless Vector control.

60.05
DC Braking Current Level Range: 0 to 100% Default: 00
Unit: 1%

This parameter determines the amount of DC Braking Current applied to the motor during start-up and stopping. When setting DC Braking current, please note that 100% is equal to the rated output current of the drive. It is recommended to start with a low DC Braking Current Level and then increase until proper holding torque has been attained.

60.06
DC Braking Time upon a Start Range: 0.0 to 5.0 seconds Default: 0.0
Unit: 0.1seconds

This parameter determines the duration of time that the DC Braking Current will be applied to the motor upon a start command of the AC drive. DC Braking will be applied for the time set in this parameter until the Minimum Frequency is reached during acceleration.

60.07
DC Braking Time upon a Stop Range: 0.0 to 25.0 seconds Default: 0.0
Unit: 0.1seconds

This parameter determines the duration of time that the DC braking current will be applied to the motor upon a stop command of the AC drive.

Parameter 50.03 must be set to RAMP to stop, for DC braking to be enabled.

60.08
Frequency Point for DC Braking

Range: 0.0 to 60.0Hz

Default: 0.0

Unit: 0.1Hz

This parameter determines the Frequency Point for DC Braking to begin upon a stop command.

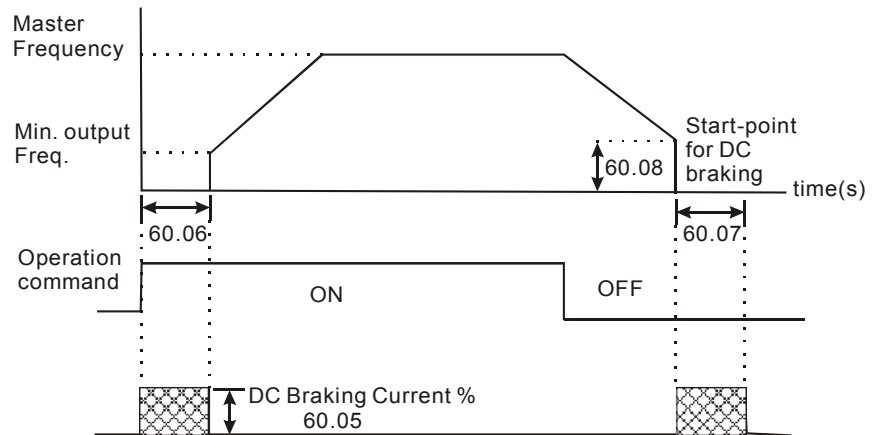

Note: DC Braking during Start-up is used for loads that may move before the AC drive starts, such as fans and pumps. These loads may also be moving in the wrong direction. Under such circumstances, DC Braking can be executed to hold the load in position before applying a forward motion.

DC Braking during stopping is used to decrease stopping time and also to hold a stopped load in position. For high inertia loads, a dynamic braking resistor may be needed for quick decelerations.

60.09
Torque Compensation

Range: 00 to 10%

Default: 00%

Units: %

This parameter selects the % of increased voltage upon acceleration of the AC drive. This is helpful during start-up to obtain a higher initial starting torque. Increased voltage to the motor also increases current and heat. Always start with a low Torque Compensation value and slowly increase until sufficient starting torque is achieved.

This parameter may be set during operation.

60.10

Slip Compensation

Range: 0.00 to 10.00

Default: 0.00 for V/F

Default: 1.00 for vector

An increasing load on an asynchronous motor will cause an increase in motor slip. This Slip Compensation parameter may be used to compensate for the nominal slip within a range of 0 to 10%.

When the output current of the AC drive is greater than the motor no-load current (60.02) the AC drive will adjust its output frequency to help keep rotor speed constant. The maximum increase in output frequency is determined by the setting of this parameter. A setting of 5% will increase output frequency from 60hz to 63hz percentage.

This parameter may be set during operation.

60.11

PWM Carrier Frequency

Range:

Default: 09

01 fc= 1KHz

02 fc= 2KHz

03 fc= 3KHz

: : :

15 fc= 15KHz

The parameter selects the carrier frequency for the PWM (Pulse-Width Modulated) function.

Carrier Frequency	Acoustic Noise	Electromagnetic Noise, Leakage Current	Heat Dissipation
1KHz	Significant	Minimal	Minimal
15KHz	Minimal	Significant	Significant

From the above table, we see that the carrier frequency for the PWM function has a significant influence on the electromagnetic noise, heat dissipation of the AC drive, and the acoustic noise of the motor.

Group 70 — Protective Functions

70.01 Over-voltage Stall Prevention

Range: Default: 01
 00 Disable Over-Voltage Stall Prevention
 01 Enable Over-Voltage Stall Prevention

During deceleration, the AC drive's DC bus voltage may exceed its maximum allowable value due to motor regeneration. When this function is enabled, the AC drive will stop decelerating, and maintain a constant output frequency. The drive will resume deceleration when the voltage drops below the factory-preset value.

Note: *With moderate inertia loads, over-voltage during deceleration will not occur. For application with high inertia loads, the AC drive will automatically extend the deceleration time. If deceleration time is critical for the application, then a dynamic braking resistor should be used.*

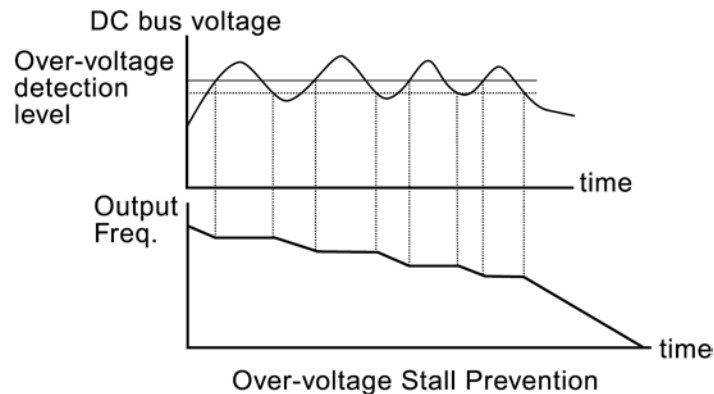

70.02 Over-Current Stall Prevention during Acceleration

Range: Default: 150%
 00: disable
 20 to 200%: enable
 Unit: 1%

A setting of 100% is equal to the Rated Output Current of the drive.

Under certain conditions, the AC drive output current may increase abruptly, and exceed the value specified by 70.02. This is commonly caused by a rapid acceleration or excessive loading on the motor. When 70.02 is enabled, the AC drive will stop accelerating and maintain a constant output frequency. The AC drive will only resume acceleration when the current drops below the value set in 70.02.

70.03
Over-Current Stall
Prevention during
Operation

Range:
 00:disable
 20 to 200%: enable

Default: 150%

Unit: 1%

During steady-state operation with the motor load rapidly increasing, the AC drive output current may exceed the limit specified in 70.03. When this occurs, the output frequency will decrease to prevent an Over Current Fault. The drive will accelerate back to the command frequency only when the output current drops below the level specified by 70.03.

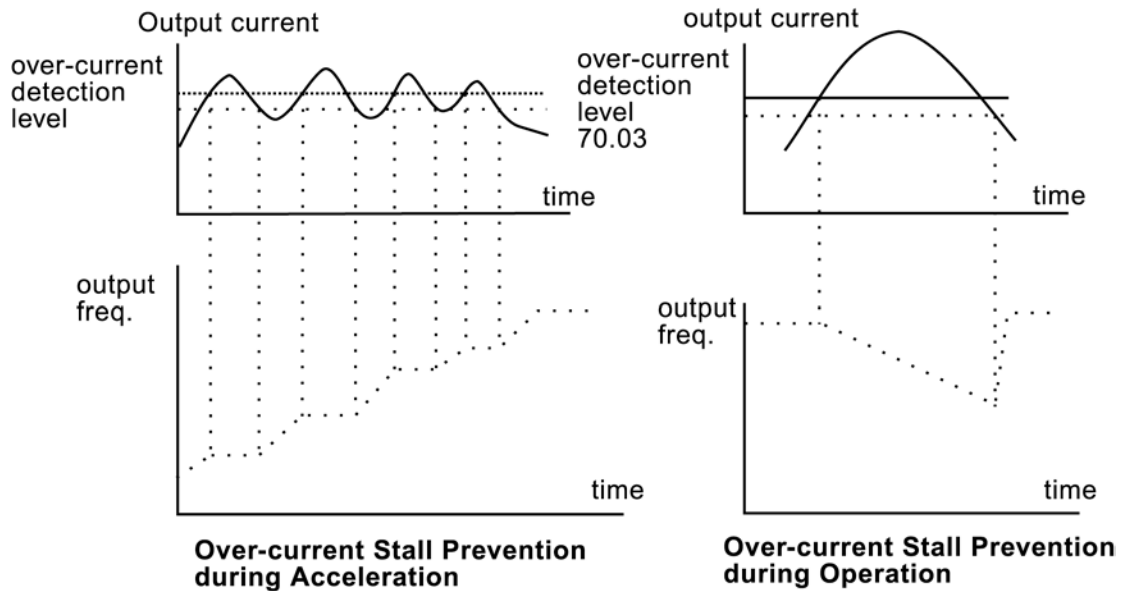

70.04
Over-Torque Detection
Mode(OL2)

- Range: Default: 00
- 00 Over-Torque detection disabled
 - 01 Over-Torque detection enabled during constant speed operation, and operation halted after Over-Torque Detection
 - 02 Over-Torque detection enabled during constant speed operation, and operation continues after Over-Torque Detection
 - 03 Over-Torque Detection enabled during operation, and operation halted after Over-Torque Detection
 - 04 Over-Torque detection enabled during acceleration, and operation continues after Over-Torque Detection

70.05
Over-Torque Detection Level Range: 30 to 200% Default: 150
Unit: 1%

A setting of 100% is proportional to the Rated Output Current of the drive.

This parameter sets the Over-Torque Detection level in 1% increments. (The AC drive rated current is equal to 100%.)

70.06
Over-Torque Detection Time Range: 0.1 to 10.0sec Default: 0.1sec
Unit: 0.1 sec

This parameter sets the Over-Torque Detection Time in units of 0.1 seconds.

70.07
Electronic Thermal Overload Relay Selection (I²t) Range: Default: 01
00 Inverter Motor (auxiliary fan cooled or high temp rated motor)
01 Standard Motor (self cooled motor, shaft mounted fan)
02 Disable

This function is used to limit the output power of the AC drive when powering a “self-cooled” motor at low speed.

70.08

Electronic Thermal Motor Overload

Range: 30 to 300 seconds

Default: 60sec

Unit: 1 seconds

This parameter can be set during operation.

The parameter determines the time required to activate the I²t electronic thermal motor overload function. The graph below shows I²t curves for, 150% output power for 1 minute.

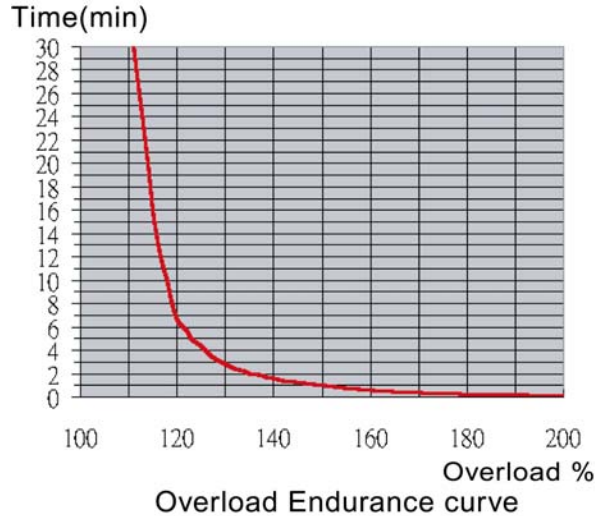
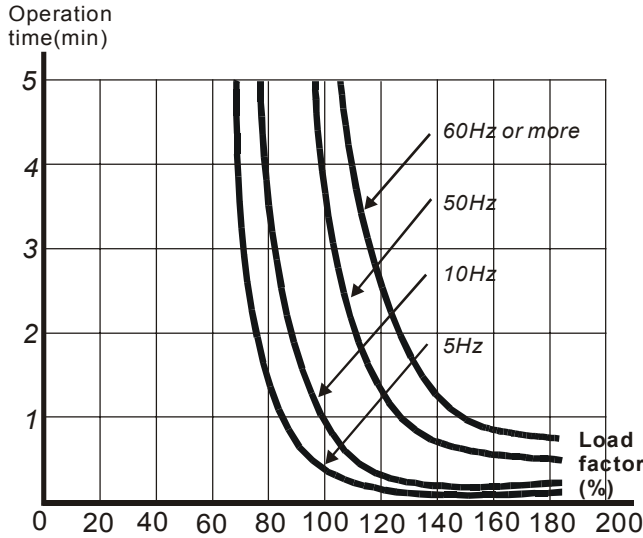

70.09

Auto Voltage Regulation (AVR)

Range:

Default: 00

- 00 AVR function enabled
- 01 AVR function disabled
- 02 AVR function disabled during deceleration
- 03 AVR function disabled upon a stop command

The AVR function automatically regulates the AC drive's output voltage to meet the value set in 50.06 (Motor Nameplate Voltage).

Example: If 50.06 is set at 200 VAC and the input voltage is varying between 200V to 264VAC, the drive's output voltage will automatically be limited to 200 VAC.

Without AVR function, the motor nameplate voltage may vary between 180V to 264VAC, due to the input voltage varying between 180V to 264 VAC.

Selecting value 2 enables the AVR function and also disables the AVR function during deceleration. This offers a quicker deceleration and is most commonly used.

70.10
Auto energy-saving Range: Default: 00
 00 Disable auto energy-saving operation
 01 Enable auto energy-saving operation

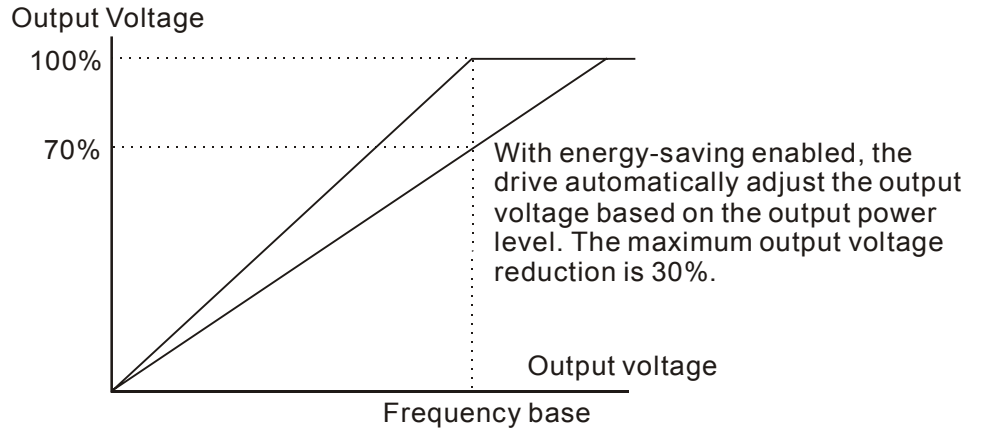

70.11
Under Current Detection Value Range: Default: 0.0
 0.0 Disabled
 0.1 to No Load Amps

The under current detection level of the AC drive. The value must be smaller than or equal to Motor No-Load current (Pr. 60.02).

70.12
Under Current Detection Mode Range: Default: 0
 0 or 1

Setting 0 = If the output current falls below Pr. 70.11, then the drive will generate an output fault via one of the digital outputs.

Setting 1 = If the output current falls below Pr. 70.11, then the drive will generate an output fault, the drive will stop and show "Uc" on the keypad display.

70.13
Under Current Detection Time Range: Default: 1.0
 0.0 to 20.0 sec.

The parameter determines the delay time before an under current output fault will occur.

Group 80 — Display

80.01
Software Version Default: xx.x

This parameter is read-only and shows the software version of the AC motor drive.

80.02
AC Drive Rated Current Display Default: xx.x

This parameter is read only and shows the rated current of the AC drive.

80.03
Manufacturer Model Information Range: Default: xx

00	MVXF50#0-2 (230V 3-Phase/1-Phase 0.5Hp input)(2.5A output)
01	MVX001#0-2 (230V 3-Phase/1-Phase 1.0Hp input)(5A output)
02	MVX002#0-2 (230V 3-Phase/1-Phase 2.0Hp input)(7A output)
03	MVX003#0-2 (230V 3-phase/1-Phase 3.0Hp input)(10A output)
04	MVX005#0-2 (230V 3-Phase 5.0Hp input)(17A output)
05	MVX075#0-2 (230V 3-Phase 7.5Hp input)(25A output)
06	Reserved
07	Reserved
08	MVX001#0-4 (460V 3-Phase 1Hp input) (3A output)
09	MVX002#0-4 (460V 3-Phase 2Hp input) (4A output)
10	MVX003#0-4 (460V 3-Phase 3Hp input) (5A output)
11	MVX005#0-4 (460V 3-phase 5Hp input) (8.2A output)
12	MVX075#0-4 (460V 3-Phase 7.5Hp input) (13A output)
13	MVX010#0-4 (460V 3-Phase 10Hp input) (18A output)

This parameter is read only and displays the drive model number.

80.04		
Present Fault Record	Range:	Default: 00
	00	(no fault occurred)
	01	Over-current (oc)
	02	Over-voltage (ov)
	03	Overheat (oH)
	04	Overload (oL)
	05	Overload 1 (oL1)
	06	Overload 2 (oL2)
	07	External Fault (EF)
	08	CPU failure 1 (CF1)
	09	CPU failure 2 (CF2)
	10	CPU failure 3 (CF3)
	11	Hardware Protection Failure (HPF)
	12	Over-current during acceleration (OCA)
	13	Over-current during deceleration (OCd)
	14	Over-current during steady state operation (OCn)
	15	Ground fault or fuse failure (GFF)
	16	Reserved
	17	3 Phase input power loss
	18	External Pause Function (bb)
	19	Auto Adjustable accel/decel failure (cFA)
	20	Software protection code (codE)
80.05		
Second Most Recent Fault Record	Range: See Parameter 80.04	Default: 00
80.06		
Third Most Recent Fault Record	Range: See Parameter 80.04	Default: 00
80.07		
Keypad Start Up Display	Range:	Default: 00
	00	Command Frequency (F)
	01	Output Frequency (H)
	02	Output Current (A)
	03	User Defined Unit (U)
	04	Output Voltage (u)
	05	Unit Temperature (t)
	06	Forward Reverse Direction (Frd) or (rEu) Counter (c) [Displayed only when enabled] PLC Steps [Displayed only when enabled] PID Feedback [Displayed only when enabled]

**80.08
User Defined Multiplier**

Range: 0.01 to 160.00 Default: 1.00
Unit: 0.01

The User Defined Multiplier selects the multiplying factor for the user-defined unit.

The display value is calculated as follows:

$$\text{Display value} = \text{output frequency} \times \text{User Defined Multiplier}$$

The display window is only capable of showing four digits, yet by using the decimals in the display area, 4 digit numbers are displayed. The decimal points change the value of the number as shown below.

Display	Number Represented
9999	The absence of a decimal point indicates a four-digit integer.
999.9	A single decimal point between the middle and the right-most numbers is a true decimal point; it separates ones and tenths as in "30.5" (thirty and one-half).
9999.	A single decimal point after the right-most number is not a true decimal point; instead it indicates that a zero follows the right-most number. For example, the number 12300 would be displayed as "1230."

This parameter can be set during operation.

**80.09
External Terminal Scan Time**

Range: 1 to 20 Default: 1
Unit: 2msec

This function scans the I/O terminals to help eliminate false signals due to noise.

$$\text{Actual Scan Time} = 80.09 \times 2 \text{ m seconds}$$

**80.10
Parameter Lock and Configuration**

Range: Default: 00
00 All parameters may be set and displayed
01 All parameters are read-only
02 to 09 Not used
10 Resets all parameters to the factory defaults

This parameter allows the user to return all parameters to Defaults.

**80.11
Run Elapsed Time (Days)**

Units: Days (read only)

80.12
Run Elapsed Time Units: Minutes (read only)
(Minutes)

80.13
Power On Elapsed Time Units: Days (read only)
(Days)

80.14
Power On Elapsed Time Units: Minutes (read only)
(Minutes)

80.15
Automatic Scroll Display Range: Default: 00
00 Disable
01 Scroll every 5 seconds after a 1 minute delay
02 Scroll every 15 seconds after a 1 minute delay

This parameter selects the automatic display scroll mode. If parameter 80.15 is set to 01 or 02, the display will scroll through all available views and repeat.

Group 90 — Communications

90.01

Communication Protocol	Range:	Default: 0
0	Modbus ASCII mode, <7,N,2>	
1	Modbus ASCII mode, <7,E,1>	
2	Modbus ASCII mode, <7,O,1>	
3	Modbus RTU mode, <8,N,2>	
4	Modbus RTU mode, <8,E,1>	
5	Modbus RTU mode, <8,O,1>	

This parameter may be set during operation.

90.02

Communication Address	Range: 01 to 254	Default: 01
------------------------------	------------------	-------------

If the AC drive is controlled by RS-485 serial communication, the communication address must be set via this parameter.

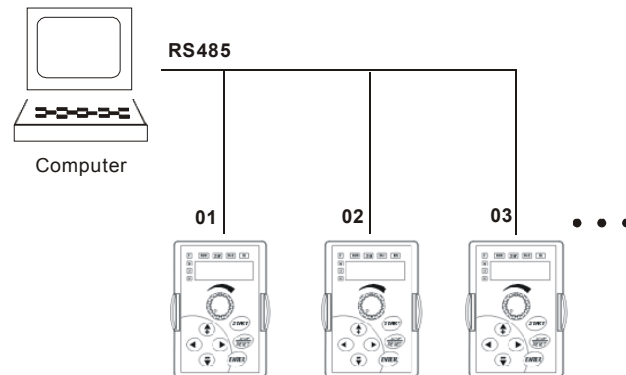

This parameter may be set during operation.

90.03

Transmission Speed	Range:	Default: 01
00	Baud rate 4800 (data transmission speed: bits / sec)	
01	Baud rate 9600 (data transmission speed: bits / sec)	
02	Baud rate 19200 (data transmission speed: bits / sec)	
03	Baud rate 38400 (data transmission speed: bits / sec)	

Users may set parameters and control the operation of the AC drive via the RS-485 serial interface. This parameter is used to set the transmission speed between the PC and the MVX9000.

This parameter may be set during operation.

90.04

Transmission Fault Treatment	Range:	Default: 03
	00	Display Fault and Continue Operating
	01	Display Fault and RAMP to Stop
	02	Display Fault and COAST to Stop
	03	No Fault Displayed and Continue Operating

90.05

Over-time Detection (Watch Dog Timer)	Range:	Default: 0.0
	0.1-120.0	seconds
	0.0	Disable

This parameter is used for communication loss. When this parameter is set to any value over 0.0, the timer is enabled. The value set in this parameter is the time allowed between two command strings.

Table 5-1 Communication Mapping Table

Modbus	Groups	Description	Range
0705H	90.06	Communication frequency reference	0.0 to 400.0Hz
0706H	90.07	Communication command	Bit 0-1: 00 no function 01 Stop 10 Run 11 JOG + Run Bit 2-3: Reserved Bit 4-5: 00 no function 01 Forward 10 Reverse 11 Change direction Bit 6-15: Reserved
0707H	90.08	Communication for EF/RESET	Bit 0: 1 EF On Bit 1: 1 Reset Bit 2-15: Reserved
0708H	90.09	Status monitor for error code	00: No Fault occurred 01: Over-current (oc) 02: Over-voltage (ov) 03: Overheat (oH) 04: Overload (oL) 05: Overload 1 (oL1) 06: Overload 2 (oL2) 07: External Fault (EF) 08: CPU failure 1 (CF1) 09: CPU failure 2 (CF2) 10: CPU failure 3 (CF3) 11: Hardware Protection Failure (HPF) 12: Over-current during accel (OCA) 13: Over-current during decel (OCd) 14: Over-current during steady state (OCn) 15: Ground fault or fuse failure (GFF) 16: Under Voltage (Lv) 17: 3 Phase Input Power Loss (PHL) 18: External Base-Block (bb) 19: Auto Adjust accel/decel failure (cFA) 20: Software protection code (codE)
0709H	90.10	Status monitor for AC drive (Bit 0-1)	00 Stop 01: Decelerate during the drive stopping 10: The drive standby 11: Run
		(Bit 2)	1: JOG active
		(Bit 3-4)	00: FWD 01: REV to FWD 10: FWD to REV 11: REV
		(Bit 5-7)	Reserved
		(Bit 8)	1: Source of frequency by communication
		(Bit 9)	1: Source of frequency by AI
		(Bit 10)	1: Source of operation by communication
		(Bit 11)	1: Parameters have been locked
		(Bit 12-15)	Reserved
070AH	90.11	Status monitor for communication frequency	0.0 to 400.0 Hz (%)
070BH	90.12	Status monitor for output frequency	0.0 to 400.0 Hz (%)
070CH	90.13	Status monitor for output current	0.0 to Max Amps
070DH	90.14	Status monitor for user defined (Low word)	0.00 to 655.35
070EH	90.15	Status monitor for user defined (Hi word)	00 to 65535
070FH	90.16	Status monitor for output voltage	0.0 to Max Vac
0710H	90.17	Status monitor for unit temperature	0.0 to Max degree C
0711H	90.18	Status monitor for DC bus voltage	0.0 to Max Vdc
0712H	90.19	Status monitor for multi-step	0 to Max step
0713H	90.20	Status monitor for time of PLC operation	00 to 65535
0714H	90.21	Status monitor for counter	00 to 65535
0715H	90.22	Feedback Signal	0.0 to 400.0 Hz (%)
0716H	90.23	PID Setpoint	0.0 to 400.0 Hz (%)

Computer Control

There is a built-in RS-485 serial interface (RJ-12 Jack) at the top of the drive near the Input power.

The pins are defined below:

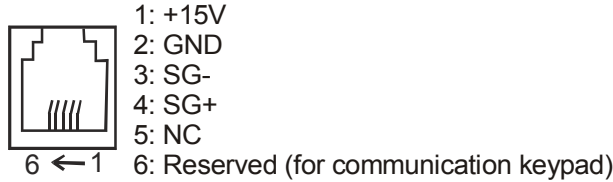

Each MVX9000 AC drive has a pre-assigned communication address specified by 90.02. The computer then controls each AC drive according to its address.

The MVX9000 can be set up to communicate on a Modbus network using one of the following modes: ASCII (American Standard Code for Information Interchange) or RTU (Remote Terminal Unit). Users can select the desired mode along with the serial port communication protocol in 90.01 and 90.03.

Code Explanation

ASCII mode:

Each 8-bit data is the combination of two ASCII characters. For example, a 1-byte data: 64 Hex, shown as '64' in ASCII, consists of '6' (36Hex) and '4' (34Hex).

Character	'0'	'1'	'2'	'3'	'4'	'5'	'6'	'7'
ASCII code	30H	31H	32H	33H	34H	35H	36H	37H

Character	'8'	'9'	'A'	'B'	'C'	'D'	'E'	'F'
ASCII code	38H	39H	41H	42H	43H	44H	45H	46H

RTU mode:

Each 8-bit data is the combination of two 4-bit hexadecimal characters. For example, 64 Hex.

Data Format

10-bit character frame (For 7-bit character):

(7.N.2 : Pr.92=0)

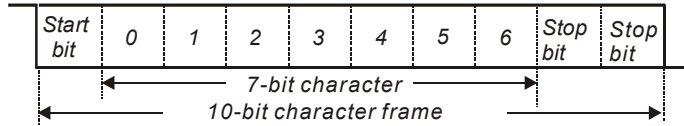

(7.E.1: Pr.92=1)

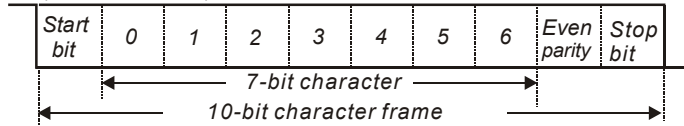

(7.O.1:Pr.92=2)

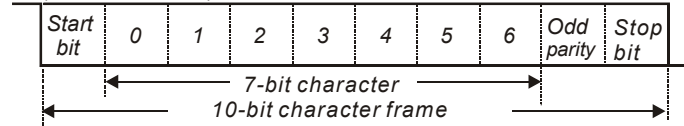

11-bit character frame (For 8-bit character):

(8.N.2:Pr.92=3)

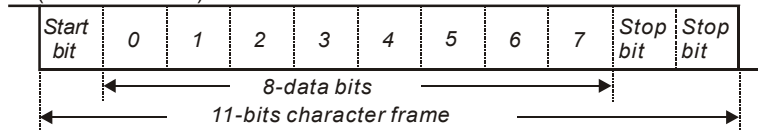

(8.E.1:Pr.92=4)

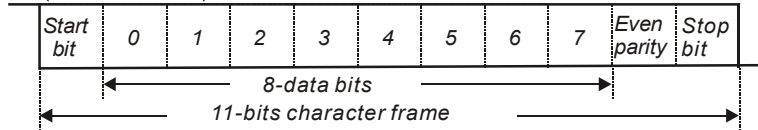

(8.O.1:Pr.92=5)

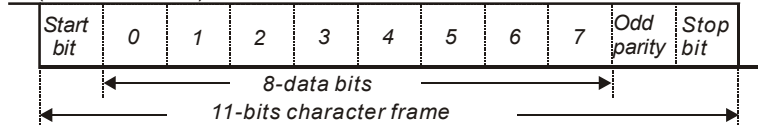

Communication Protocol

STX	ADR 1	ADR 0	CMD 1	CMD 0	0	1	N-1	N	ETX	CHK 1	CHK 0
02H	Address			CMD	Data characters				03H	Check Sum		

ASCII Mode

STX	Start character: (3AH)
ADR 1	Communication address: 8-bit address consists of 2 ASCII codes
ADR 0	
CMD 1	
CMD 0	
DATA (n-1)	Contents of data: Maximum: 20-word registers
.....	
DATA 0	
LRC	LRC check sum: 8-bit check sum consists of 2 ASCII codes
CHK 1	
LRC	
CHK 0	END characters: END 1 = CR (0DH), END 0 = LF (0AH)
END 1	
END 0	

RTU Mode

START	A silent interval of more than 10 ms
ADR	Communication address: 8-bit address
CMD	Command code: 8-bit command
DATA (n-1)	Contents of data: Maximum: 20-word registers
.....	
DATA 0	
CRC CHK Low	CRC check sum: 16-bit check sum consists of 2 8-bit characters
CRC CHK High	
END	

ADR (Communication Address)

Valid communication addresses are in the range of 0 to 254. A Communication address equal to 0 means broadcast to all AC drives. In this case, the MVX9000 will not reply with any message to the master device.

For example, communication to MVX9000 with address 16 decimal:

ASCII mode: (ADR 1, ADR 0)='1','0' => '1'=31H, '0'=30H

RTU mode: (ADR)=10H

CMD (Command code) and DATA (data characters)

The format of data characters depends on the command code. The available command codes are described as follows: Command code: 03H, read N words. The maximum value of N is 12. For example, reading continuous 2 words from starting address 2102H of AMD with address 01H.

ASCII mode:

Command message:

STX	':'
ADR 1	'0'
ADR 0	'1'
CMD 1	'0'
CMD 0	'3'
Starting data address	'2'
	'1'
	'0'
	'2'
Number of data (Count by word)	'0'
	'0'
	'2'
LRC CHK 1	'D'
LRC CHK 0	'7'
END 1	CR
END 0	LF

Response message:

STX	':'
ADR 1	'0'
ADR 0	'1'
CMD 1	'0'
CMD 0	'3'
Number of data (Count by byte)	'0'
	'4'
Content of starting data address 2102H	'1'
	'7'
	'0'
Content of data address 2103H	'0'
	'0'
	'0'
LRC CHK 1	'7'
LRC CHK 0	'1'
END 1	CR
END 0	LF

RTU mode:

Command message:

ADR	01H
CMD	03H
Starting data address	21H
	02H
Number of data (count by word)	00H
	02H
CRC CHK Low	6FH
CRC CHK High	F7H

Response message:

ADR	01H
CMD	03H
Number of data (Count by byte)	04H
Content of data address 2102H	17H
	70H
Content of data address 2103H	00H
	00H
CRC CHK Low	FEH
CRC CHK High	5CH

Command code: 06H, write 1 word

For example, writing 6000 (1770H) to address 0100H of MVX9000 with address 01H.

ASCII mode:

Command message:

STX	‘.’
ADR 1	‘0’
ADR 0	‘1’
CMD 1	‘0’
CMD 0	‘6’
	‘0’
	‘1’
	‘0’
	‘0’
Data address	‘1’
	‘7’
	‘7’
	‘0’
LRC CHK 1	‘7’
LRC CHK 0	‘1’
END 1	CR
END 0	LF

Response message:

STX	‘.’
ADR 1	‘0’
ADR 0	‘1’
CMD 1	‘0’
CMD 0	‘6’
	‘0’
	‘1’
Data address	‘0’
	‘0’
	‘1’
Data content	‘7’
	‘7’
	‘0’
LRC CHK 1	‘7’
LRC CHK 0	‘1’
END 1	CR
END 0	LF

RTU mode:

Command message:

ADR	01H
CMD	06H
Data address	01H
	00H
Data content	17H
	70H
CRC CHK Low	86H
CRC CHK High	22H

Response message:

ADR	01H
CMD	06H
Data address	01H
	00H
Data content	17H
	70H
CRC CHK Low	86H
CRC CHK High	22H

CHK (check sum)

ASCII mode:

LRC (Longitudinal Redundancy Check) is calculated by summing up, module 256, the values of the bytes from ADR1 to last data character then calculating the hexadecimal representation of the 2's-complement negation of the sum.

For example, reading 1 word from address 0401H of the AC drive with address 01H

STX	'.'
ADR 1	'0'
ADR 0	'1'
CMD 1	'0'
CMD 0	'3'
Starting data address	'0'
	'4'
	'0'
	'1'

	'0'
	'0'
	'0'
	'1'
LRC CHK 1	'F'
LRC CHK 0	'6'
END 1	CR
END 0	LF

01H+03H+04H+01H+00H+01H=0AH,
the 2's-complement negation of 0AH is
F6H.

RTU mode:

ADR	01H
CMD	03H
Starting address	21H
	02H
Number of data (count by word)	00H
	02H
CRC CHK Low	6FH
CRC CHK High	F7H

CRC (Cyclical Redundancy Check) is calculated by the following steps:

Step 1: Load a 16-bit register (called CRC register) with FFFFH.

Step 2: Exclusive OR the first 8-bit byte of the command message with the low order byte of the 16-bit CRC register, putting the result in the CRC register.

Step 3: Shift the CRC register one bit to the right with MSB zero filling. Extract and examine the LSB.

Step 4: If the LSB of CRC register is 0, repeat step 3, else Exclusive or the CRC register with the polynomial value A001H.

Step 5: Repeat step 3 and 4 until eight shifts have been performed. When this is done, a complete 8-bit byte will have been processed.

Step 6: Repeat steps 2 to 5 for the next 8-bit byte of the command message.

Continue doing this until all bytes have been processed. The final contents of the CRC register are the CRC value. When transmitting the CRC value in the message, the upper and lower bytes of the CRC value must be swapped, i.e. the lower order byte will be transmitted first.

The following is an example of CRC generation using C language. The function takes two arguments:

Unsigned char* data ← a pointer to the message buffer

Unsigned char length ← the quantity of bytes in the message buffer

The function returns the CRC value as a type of unsigned integer.

```

Unsigned int crc_chk(unsigned char* data, unsigned char length){
    int j;
    unsigned int reg_crc=0xFFFF;
    while(length--){
        reg_crc ^= *data++;
        for(j=0;j<8;j++){
            if(reg_crc & 0x01){ /* LSB(b0)=1 */
                reg_crc=(reg_crc>>1) ^ 0xA001;
            }else{
                Reg_crc=reg_crc>>1;
            }
        }
    }
    return reg_crc;
}

```

Communication program of PC:

The following is a simple example of how to write a communication program for Modbus ASCII mode on a PC using C language.

```
#include<stdio.h>
#include<dos.h>
#include<conio.h>
#include<process.h>
#define PORT 0x03F8 /* the address of COM1 */
/* the address offset value relative to COM1 */
#define THR 0x0000
#define RDR 0x0000
#define BRDL 0x0000
#define IER 0x0001
#define BRDH 0x0001
#define LCR 0x0003
#define MCR 0x0004
#define LSR 0x0005
#define MSR 0x0006

unsigned char rdat[60];
/* read 2 data from address 2102H of AC drive with address 1 */
unsigned char tdat[60]={':', '0', '1', '0', '3', '2', '1', '0', '2',
'0', '0', '0', '2', 'D', '7', '\r', '\n'};

void main(){
    int i;
    outportb(PORT+MCR,0x08); /* interrupt enable */
    outportb(PORT+IER,0x01); /* interrupt as data in */
    outportb(PORT+LCR,(inportb(PORT+LCR) | 0x80));
    /* the BRDL/BRDH can be access as LCR.b7==1 */
    outportb(PORT+BRDL,12); /* set baudrate=9600,
12=115200/9600*/
    outportb(PORT+BRDH,0x00);
    outportb(PORT+LCR,0x06); /* set protocol, <7,N,2>=06H
<7,E,1>=1AH, <7,O,1>=0AH
<8,N,2>=07H, <8,E,1>=1BH
<8,O,1>=0BH */
    for(i=0;i<=16;i++){
        while(!(inportb(PORT+LSR) & 0x20)); /* wait until THR empty */
        outportb(PORT+THR,tdat[i]); /* send data to THR */
    }
    i=0;
    while(!kbhit()){
        if(inportb(PORT+LSR) & 0x01){ /* b0==1, read data ready */
            rdat[i++]=inportb(PORT+RDR); /* read data form RDR */
        } } }
}
```

Chapter 6 – Maintenance and Inspection

Modern AC drives are based on solid state electronics technology. Preventive maintenance is required to operate this AC drive in optimal condition, and to ensure a long life. A monthly check up of the AC drive by a qualified technician is recommended. Before the check up, always turn off the AC Input Power to the unit.

Wait at least 2 minutes after all display lamps have gone out, and then confirm that the capacitors have fully discharged by measuring the voltage between B1 and Ground using a multi meter set to measure DC.

Periodic Inspection

Check the following periodically to detect:

- Whether the motors are operating as expected.
- Whether the installation environment is abnormal.
- Whether the cooling system is operating as expected.
- Whether any irregular vibration or sound occurred during the operation.
- Whether the motors are overheating during the operation.

Note: Always check the input voltage of the AC drive with a Voltmeter.

Periodic Maintenance



WARNING!

Disconnect AC power before proceeding!

1. Tighten the AC drive input and output power screws if necessary. These screws might loosen due to vibration or temperature changes.
2. Check if the conductors or insulators are corroded and damaged.
3. Check the insulation resistance with Mega-ohm meters.
4. If the AC drive is not to be used for a long periods of time, turn the power on at least once every two years and confirm that it still functions properly. To confirm functionality, disconnect the motor and energize the AC drive for at least 5 hours before attempting to run a motor with it.
5. Clean off any dust and dirt with a vacuum cleaner. Place special emphasis on cleaning the ventilation ports and PCBs. Always keep these areas clean, as accumulation of dust and dirt can cause unforeseen failures.

This page intentionally left blank.

Chapter 7 – Troubleshooting and Fault Information

The AC drive has a comprehensive fault diagnostic system that includes several different alarms and fault messages. Once a fault is detected, the corresponding protective functions will be activated. The following faults are displayed as shown on the AC drive digital keypad display. The three most recent faults can be read on the digital keypad display by viewing 80.04 through 80.06.

Note: Faults can be cleared by resetting at the keypad or with the Input Terminal.

Common Problems and Solutions

Fault Name	Fault Descriptions	Corrective Actions
OC	The AC drive detects an abnormal increase in current.	<ol style="list-style-type: none"> 1. Check that the motor horsepower corresponds to the AC drive output power. 2. Check the wiring connections between the AC drive and motor for possible short circuits. 3. Increase the acceleration time (20.08). 4. Check for possible excessive loading conditions at the motor. 5. If there are any abnormal conditions when operating the AC drive after a short circuit is removed, it should be sent back to manufacturer.
Ou	The AC drive detects that the DC bus voltage has exceeded its maximum allowable value.	<ol style="list-style-type: none"> 1. Check that the input voltage falls within the rated AC drive input voltage. 2. Check for possible voltage transients. 3. Bus over-voltage may also be caused by motor regeneration. Either increase the deceleration time or add an optional braking resistor. 4. Check whether the required braking power is within the specified limits.
oh	The AC drive temperature sensor detects excessive heat.	<ol style="list-style-type: none"> 1. Make sure that the ambient temperature falls within the specified temperature range. 2. Make sure that the ventilation holes are not obstructed. 3. Remove any foreign objects from the heatsink and check for possible dirty heat sink fins. 4. Provide enough spacing for adequate ventilation.
Lu	The AC drive detects that the DC bus voltage has fallen below its minimum value.	Check that the input voltage falls within the rated AC drive's input voltage.

Fault Name	Fault Descriptions	Corrective Actions
OL	The AC drive detects excessive drive output current. Note: The AC drive can withstand up to 150% of the rated current for a maximum of 60 seconds.	<ol style="list-style-type: none"> 1. Check if the motor is overloaded. 2. Reduce the torque compensation setting in 60.09. 3. Replace the AC drive with one that has a higher output capacity (next HP size).
OL1	Internal electronic overload trip	<ol style="list-style-type: none"> 1. Check for possible motor overload. 2. Check electronic thermal overload setting. 3. Increase motor capacity. 4. Reduce the current level so that the drive output current does not exceed the value set by the Motor Rated Current (60.01).
OL2	Motor overload. Check the parameter settings (70.04 through 70.06)	<ol style="list-style-type: none"> 1. Reduce the motor load. 2. Adjust the over-torque detection setting to an appropriate setting.
ocA	Over-current during acceleration: <ol style="list-style-type: none"> 1. Short-circuit at motor output. 2. Torque boost too high. 3. Acceleration time too short. 4. AC drive output capacity is too small. 	<ol style="list-style-type: none"> 1. Check for possible poor insulation at the output line. 2. Decrease the torque boost setting in 60.09. 3. Increase the acceleration time. 4. Replace the AC drive with one that has a higher output capacity (next HP size).
ocd	Over-current during deceleration: <ol style="list-style-type: none"> 1. Short-circuit at motor output. 2. Deceleration time too short. 3. AC drive output capacity is too small. 	<ol style="list-style-type: none"> 1. Check for possible poor insulation at the output line. 2. Increase the deceleration time. 3. Replace the AC drive with one that has a higher output capacity (next HP size).
ocn	Over-current during steady state operation: <ol style="list-style-type: none"> 1. Short-circuit at motor output. 2. Sudden increase in motor loading. 3. AC drive output capacity is too small. 	<ol style="list-style-type: none"> 1. Check for possible poor insulation at the output line. 2. Check for possible motor stall. 3. Replace the AC drive with one that has a higher output capacity (next HP size).
cf1	Internal memory cannot be programmed.	<ol style="list-style-type: none"> 1. Switch off power supply. 2. Check whether the input voltage falls within the rated AC drive input voltage. <p>Switch the AC drive back on.</p>
cf2	Internal memory cannot be read.	<ol style="list-style-type: none"> 1. Check the connections between the main control board and the power board. 2. Reset the drive to factory defaults.
HPF	Hardware protection failure	Return the drive to the factory.

Fault Name	Fault Descriptions	Corrective Actions
codE	Software protection failure	Return the drive to the factory.
cF3	Drive's internal circuitry is abnormal.	<ol style="list-style-type: none"> 1. Switch off power supply. 2. Check whether the input voltage falls within the rated AC drive input voltage. Switch on the AC drive.
EF	The external terminal DI1-COM goes from OFF to ON.	When external terminal DI1-COM is closed, the drive's output will be turned off and will display EF.
cFA	Auto acceleration/deceleration failure	Don't use the auto acceleration/ deceleration function.
OFF	Ground fault: The AC drive output is abnormal. When the output terminal is grounded (short circuit current is 50% more than the AC drive rated current), the AC drive power module may be damaged. The short circuit protection is provided for AC drive protection, not user protection.	<p>Ground fault:</p> <ol style="list-style-type: none"> 1. Check whether the IGBT power module is damaged. 2. Check for possible poor insulation on the output wires or on the motor.
bb	External Pause. AC drive output is turned off.	<ol style="list-style-type: none"> 1. When the external input terminal (pause) is active, the AC drive output will be turned off. 2. Disable this (pause) and the AC drive will begin to work again.

Warning codes

Warning Name	Warning Descriptions	Corrective Actions
CE01	Illegal command code. The command code received in the command message is not available for the AC drive.	The corrective action can be set with the Transmission Fault Treatment parameter 90.04.
CE02	Illegal data address. The data address received in the command message is not available for the AC drive.	
CE03	Illegal data value. The data value received in the command message is not available for the AC drive.	
CE04	Slave device failure. The AC drive is unable to perform the requested action.	
CE10	Communication time out	
OL2	Motor overload. Check the parameter settings 70.04 - 70.06.	1. Reduce the motor load. 2. Adjust the over-torque detection setting to an appropriate setting.
FbE	PID feedback loss	The corrective action can be set with treatment of the erroneous feedback signals parameter 50.42.
AuE	Auto Tune Error	Check whether the AC drive's wiring is correct.
SE1	Copy Keypad check error for saving the date of each parameter.	Check whether the communication wiring is correct and function is normal. It allows copying when the voltage and horsepower is the same.
SE2	The Drive check error for saving to the drive.	Check whether the communication wiring is correct and function is normal. It allows copying when the voltage and horsepower is the same.
Uc	Under current fault.	Check parameters 70.11 to 70.13.

Appendix A – Technical Data

Voltage Class		230V Series					
Model Number MVX__AO-		F50	001	002	003	005	007
Max. Applicable Motor Output (kW)		0.4	0.75	1.5	2.2	3.7	5.5
Max. Applicable Motor Output (HP)		0.5	1	2	3	5	7.5
Output Rating	Rated Output Capacity (kVA)	1	1.9	2.7	3.8	6.5	9.5
	Rated Output Current (A)	2.5	5	7	10	17	25
	Max. Output Voltage (V)	Proportional to input voltage					
	Rated Frequency (Hz)	0.1 to 400 Hz					
Input Rating	Rated Voltage	180 to 264 VAC					
	Frequency Tolerance	50/60 Hz ±5%					
	1 phase/3 phase Rated Input Current	6.3/3.2	11.5/6.3	15.7/9	27/15	19.6	28
Control Characteristics	Control System		SPWM (Sinusoidal Pulse Width Modulation)				
	Output Frequency Resolution		0.1Hz				
	Overload Endurance		150% of rated current for 1 minute				
	Acceleration/Deceleration Time		0.01 to 600.00 seconds				
	Torque Characteristics		Including the auto-torque, auto-slip compensation; starting torque can be 150% at 1Hz in vector, 3Hz in V/F				
	V/F Pattern		Adjustable V/F pattern or sensorless vector				
	Stall Prevention Level		Set to percentage of rated current				
Operating Characteristics	Frequency Setting	Keypad	Set by UP, DOWN keys or potentiometer				
		External Signal	Potentiometer-5KW/0.5W, 0 to +10VDC or 0 to +5V (Input impedance 47KW), RS-485 interface, 4 to 20mA (Input impedance 250Ω), 1 to 7 step speeds, PID feedback				
	Operation Setting Signal	Keypad	Set by START, STOP, RIGHT and LEFT keys				
		External Signal	FWD/STOP, REV/STOP (RUN/STOP, FWD/REV), 3-wire control, serial communication				
	Digital Input Signal		Multi-step selections 1 to 7, Jog, acceleration/deceleration inhibit, first/second acceleration/deceleration switch, counter, External BB (Pause), PLC operation. Terminals have 5V potential and must be brought to DC common to enable (Sinking).				
	Digital Output Indication		Operating, Up to frequency, Desired frequency, Non-zero B.B., Abnormal indication, Local/Remote indication, PLC, Low Voltage.				
	Analog Output Signal		Analog frequency/current signal output.				
Other Functions		AVR, S-Curve, Over-Voltage, Over-Current stall prevention, Fault records checking, Carrier Frequency adjustable, DC injection braking, Momentary power loss restart, Frequency limit setting, Parameter lock/reset, Frequency input operation method selection, Reverse run inhibit, etc.					
Protection		Self-testing, Over-voltage, Over-current, Under-voltage, Overload, Overheating, External Fault, Ground Fault, I ² t.					
Cooling Systems		Forced air-cooling					
Environment	Installation Location		Altitude 1,000 m or lower, keep from corrosive gasses, liquid and dust				
	Pollution Degree		2				
	Ambient Temperature		-10°C to 50°C (Non-Condensing and not frozen)-10°C to 40°C for the models of 5.5kW and higher				
	Storage Temperature		-20°C to 60°C				
	Ambient Humidity		Below 90% RH (non-condensing)				
Vibration		9.80665 m/s ² (1G) less than 20Hz, 5.88m/s ² (0.6G) at 20 to 50Hz					

Voltage Class		460V Series					
Model Number MVX__AO-		001	002	003	005	007	010
Max. Applicable Motor Output (kW)		0.75	1.5	2.2	3.7	5.5	7.5
Max. Applicable Motor Output (HP)		1	2	3	5	7.5	10
Output Rating	Rated Output Capacity (kVA)	2.3	3.1	3.8	6.2	9.9	13.7
	Rated Output Current (A)	3	4	5	8.2	13	18
	Max. Output Voltage (V)	Proportional to input voltage					
	Rated Frequency (Hz)	0.1 to 400 Hz					
Input Rating	Rated Voltage	342 to 528 VAC					
	Frequency Tolerance	50/60 Hz ±5%					
	3 phase Rated Input Current	4.2	5.7	6	8.5	14	23
Control Characteristics	Control System	SPWM (Sinusoidal Pulse Width Modulation)					
	Output Frequency Resolution	0.1Hz					
	Overload Endurance	150% of rated current for 1 minute					
	Acceleration/Deceleration Time	0.01 to 600.00 seconds					
	Torque Characteristics	Including the auto-torque, auto-slip compensation; starting torque can be 150% at 1Hz in vector, 3Hz in V/F					
	V/F Pattern	Adjustable V/F pattern or sensorless vector					
	Stall Prevention Level	Set to percentage of rated current					
Operating Characteristics	Frequency Setting	Keypad	Set by UP, DOWN keys or potentiometer				
		External Signal	Potentiometer-5KW/0.5W, 0 to +10VDC or 0 to +5V (Input impedance 47KW), RS-485 interface, 4 to 20mA (Input impedance 250Ω), 1 to 7 step speeds, PID feedback				
	Operation Setting Signal	Keypad	Set by START, STOP, RIGHT and LEFT keys				
		External Signal	FWD/STOP, REV/STOP (RUN/STOP, FWD/REV), 3-wire control, serial communication				
	Digital Input Signal	Multi-step selections 1 to 7, Jog, acceleration/deceleration inhibit, first/second acceleration/deceleration switch, counter, External BB (Pause), PLC operation. Terminals have 5V potential and must be brought to DC common to enable (Sinking).					
	Digital Output Indication	Operating, Up to frequency, Desired frequency, Non-zero B.B., Abnormal indication, Local/Remote indication, PLC, Low Voltage.					
Analog Output Signal	Analog frequency/current signal output.						
Other Functions		AVR, S-Curve, Over-Voltage, Over-Current stall prevention, Fault records checking, Carrier Frequency adjustable, DC injection braking, Momentary power loss restart, Frequency limit setting, Parameter lock/reset, Frequency input operation method selection, Reverse run inhibit, etc.					
Protection		Self-testing, Over-voltage, Over-current, Under-voltage, Overload, Overheating, External Fault, Ground Fault, I ² t.					
Cooling Systems		Forced air-cooling					
Environment	Installation Location	Altitude 1,000 m or lower, keep from corrosive gasses, liquid and dust					
	Pollution Degree	2					
	Ambient Temperature	-10°C to 50°C (Non-Condensing and not frozen)-10°C to 40°C for the models of 5.5kW and higher					
	Storage Temperature	-20°C to 60°C					
	Ambient Humidity	Below 90% RH (non-condensing)					
	Vibration	9.80665 m/s ² (1G) less than 20Hz, 5.88m/s ² (0.6G) at 20 to 50Hz					

Appendix B – Parameter Tables

MVX9000 Parameter Listing

20 — BASIC GROUPING (Quick Start)

Modbus	Groups	Page #	Description	Range	default	User settings
0000H	20.01 50.05	5-4	Motor Nameplate Frequency	10.0 to 400.0 Hz	60.0	
0001H	20.02 50.06	5-4	Motor Nameplate Voltage	230V drives: 2.0 to 255 V	230	
				460V drives: 2.0 to 510 V	460	
0002H	20.03 50.01	5-4	Source of Master Frequency	00: Master frequency determined by digital keypad up/down	01	
				01: Master frequency determined by keypad potentiometer		
				02: Master frequency determined by 0 to +10V input on AI terminal		
				03: Master frequency determined by 4 to 20mA input on AI terminal		
				04: Master frequency determined by RS-485 communication interface		
0003H	20.04 50.02	5-4	Source of Operation command	00: Operation commands by digital keypad	00	
				01: Operation commands by external control terminals, keypad STOP is effective		
				02: Operation commands by external control terminals, keypad STOP is ineffective		
				03: Operation commands by RS-485 interface, keypad STOP is effective		
				04: Operation commands by RS-485 interface, keypad STOP is ineffective		
0004H	20.05 60.01	5-5	Motor Rated Current	30 to 120 %	FLA	
0005H	20.06 50.09	5-5	Minimum Output Frequency	0.1 to 20.0 Hz	1.5	
0006H	20.07 50.04	5-5	Maximum Output Frequency	50.0 to 400.0 Hz	60.0	
0007H	20.08 50.12	5-5	Acceleration Time 1	0.01 to 600.0 sec	10.0	
0008H	20.09 50.13	5-5	Deceleration Time 1	0.01 to 600.0 sec	10.0	

30 — INPUTS

Modbus	Groups	Page #	Description	Range	default	User settings
0100H	30.01	5-6	Minimum reference value (0-10V)	0.0 to 10.0 V	0.0	
0101H	30.02	5-6	Maximum reference value (0-10V)	0.0 to 10.0 V	10.0	
0102H	30.03	5-6	Invert reference signal (0-10V)	00: Not inverted 01: Inverted	00	
0103H	30.04	5-6	Minimum reference value (4-20mA)	0.0 to 20.0 mA	4.0	
0104H	30.05	5-6	Maximum reference value (4-20mA)	0.0 to 20.0 mA	20.0	
0105H	30.06	5-6	Invert reference signal (4-20mA)	00: Not inverted 01: Inverted	00	
0106H	30.07	5-7	Potentiometer Offset	0.0 to 100.0 %	0.0	
0107H	30.08	5-7	Potentiometer Bias Polarity	00: Positive , 01: Negative	00	
0108H	30.09	5-7	Potentiometer Slope	0.1 to 300.0 %	100.0	
0109H	30.10	5-7	Potentiometer Direction	00: Forward Motion Only 01: Reverse Motion Enable	00	
010AH	30.11	5-13	Digital Input Terminal (DI1, DI2)	01: DI1-FWD / STOP, DI2-REV / STOP 02: DI1-RUN / STOP, DI2-REV / FWD 03: DI1 - RUN momentary (N.O.), DI2 - REV / FWD, DI3 - STOP momentary (N.C.)	02	
010BH	30.12	5-14	Digital Input Terminal (DI3) Digital Input Terminal (DI4) Digital Input Terminal (DI5) Digital Input Terminal (DI6)	00: Not used	05 06 07 03	
010CH	30.13			01: External Fault (N.O.)		
010DH	30.14			02: External Fault (N.C.)		
010EH	30.15			03: External Reset (N.O.)		
				04: External Reset (N.C.)		
				05: Multi-Speed 1		
				06: Multi-Speed 2		
				07: Multi-Speed 3		
				08: Jog		
				09: Second Acceleration/Deceleration Time		
				10: Control Place: I/O Terminal		
				11: Control Place: Keypad		
				12: Control Place: Communication		
				13: Increase Speed		
		14: Decrease Speed				
		15: Forward/Reverse				
		16: Parameter Lock				
		17: Acceleration/Deceleration I Prohibit				
		18: Run Enable				
		19: Base Block (N.O.)				
		20: Base Block (N.C.)				
		21: PID Disable				
		22: Run PLC Program				
		23: Pause PLC Program				
		24: Counter Trigger signal				
		25: Counter Reset				
		26: First / second Source of Master Frequency				

Modbus	Groups	Page #	Description	Range	default	User settings
010FH	30.16	5-22	Final Count Value	00 to 9999	00	
0110H	30.17	5-22	Intermediate Count Value	00 to 9999	00	
0111H	30.18	5-22	1st Preset Speed	0.0 to 400.0 Hz (100.0%)	0.0	
0112H	30.19	5-22	2nd Preset Speed	0.0 to 400.0 Hz (100.0%)	0.0	
0113H	30.20	5-23	3rd Preset Speed	0.0 to 400.0 Hz (100.0%)	0.0	
0114H	30.21	5-23	4th Preset Speed	0.0 to 400.0 Hz (100.0%)	0.0	
0115H	30.22	5-23	5th Preset Speed	0.0 to 400.0 Hz (100.0%)	0.0	
0116H	30.23	5-23	6th Preset Speed	0.0 to 400.0 Hz (100.0%)	0.0	
0117H	30.24	5-23	7th Preset Speed	0.0 to 400.0 Hz (100.0%)	0.0	
0118H	30.25	5-23	Display Hz or %	00: Frequency (Hz)	00	
				01: Percentage (%)		
0119H	30.26	5-23	Extension Input DI7	same 30.12 to 30.15	00	
011AH	30.27	5-23	Extension Input DI8	same 30.12 to 30.15	00	

40 — OUTPUTS

Modbus	Groups	Page #	Description	Range	default	User settings
0200H	40.01	5-24	Analog Output Signal	00: Frequency Hz	00	
				01: Current A		
				02: Feedback signal 0-100		
				03: Output Power 0-100%		
0201H	40.02	5-24	Analog Output Gain	00 to 200 %	100	
0202H 0203H	40.03 40.04	5-25	Digital Output Terminal (DO1-DCM) Relay Output Terminal (RO1, RO2, RO3)	00: Not used	02 03	
				01: Ready		
				02: Inverter Running		
				03: Inverter Fault		
				04: Warning (PID feedback loss, communication fault)		
				05: At speed		
				06: Zero speed		
				07: Above Desired Frequency (40.05)		
				08: Below Desired Frequency (40.05)		
				09: PID supervision		
				10: Over Voltage Warning		
				11: Over Heat Warning		
				12: Over Current Stall Warning		
				13: Over Voltage Stall Warning		
14: Low voltage						
15: PLC Program running						
16: PLC Program Step completed						
17: PLC Program completed						
18: PLC Operation paused						
19: Final count value attained						
20: Intermediate count value attained						
21: Reverse direction notification						
22: Under current detection						
0204H	40.05	5-27	Desired Frequency Attained	0.0 to 400.0 Hz	0.0	
0205H	40.06	5-27	Digital Output (RO4, RO5, RO6)	same as 40.03 to 40.04	0	
0206H	40.07	5-27	Digital Output (RO7, RO8, RO9)	same as 40.03 to 40.04	0	

50 — DRIVE CONTROL

Modbus	Groups	Page #	Description	Range	default	User settings
0300H	50.01	5-28	Source of Master Frequency	00: Master Frequency determined by digital keypad up/down	01	
				01: Master Frequency determined by keypad potentiometer		
				02: Master Frequency determined by 0 to +10V input on AI1 terminal		
				03: Master Frequency determined by 4 to 20mA input on AI2 terminal		
				04: Master Frequency determined by RS-485 communication interface		
0301H	50.02	5-28	Source of Operation Command	00: Operation command by digital keypad	00	
				01: Operation command by external control terminals, keypad STOP is effective		
				02: Operation command by external control terminals, keypad STOP is ineffective		
				03: Operation command by RS-485 interface, keypad STOP is effective		
				04: Operation command by RS-485 interface, keypad STOP is ineffective		
0302H	50.03	5-28	Stop Methods	00: Ramp to Stop	00	
				01: Coast to Stop		
0303H	50.04	5-29	Maximum Output Frequency	50.0 to 400.0 Hz	60.0	
0304H	50.05	5-29	Motor Nameplate Frequency	10.0 to 400.0 Hz	60.0	
0305H	50.06	5-29	Motor Nameplate Voltage	230V 0.1 to 255.0 V	230.0	
				460V 0.1 to 510.0 V	460.0	
0306H	50.07	5-29	Mid-point Frequency	0.1 to 400.0 Hz	1.5	
0307H	50.08	5-30	Mid-point Voltage	230V 0.1 to 255.0 V	10.0	
				460V 0.1 to 510.0 V	20.0	
0308H	50.09	5-30	Minimum Output Freq	0.1 to 20.0 Hz	1.5	
0309H	50.10	5-30	Minimum Output Voltage	230V 0.1 to 50.0 V	10.0	
				460V 0.1 to 100.0 V	20.0	
030AH	50.11	5-30	Sensorless Vector Enable	00: Disable	00	
				01: Enable		
030BH	50.12	5-32	Acceleration Time 1	0.01 to d 600.0 sec	10.00	
030CH	50.13	5-32	Deceleration Time 1	0.01 to d 600.0 sec	10.00	
030DH	50.14	5-32	Acceleration Time 2	0.01 to d 600.0 sec	10.00	
030EH	50.15	5-32	Deceleration Time 2	0.01 to d 600.0 sec	10.00	
030FH	50.16	5-33	Transition Point for Acceleration 1 to Acceleration 2	0.0:Disable	0.0	
				Above min freq.: Enable, 0.0 to 400.0 Hz		
0310H	50.17	5-33	Transition Point for Deceleration 1 to Deceleration 2	0.0:Disable	0.0	
				Above min freq.: Enable, 0.0 to 400.0 Hz		
0311H	50.18	5-33	Acceleration S-curve	00 to 07	00	
0312H	50.19	5-33	Deceleration S-curve	00 to 07	00	
0313H	50.20	5-34	Jog Acceleration / Deceleration Time	0.01 to d 600.0 sec	1.00	
0314H	50.21	5-34	Jog Frequency	0.1 to 400.0 Hz	6.0	

Modbus	Groups	Page #	Description	Range	default	User settings
0315H	50.22	5-34	Reserve Operation Enable	00: Enable Reverse Operation 01: Disable Reverse Operation	00	
0316H	50.23	5-35	Momentary Power Loss (Ride Through)	00: Stop operation after momentary power loss 01: Continue operation after momentary power loss, speed search from Speed Reference 02: Continue operation after momentary power loss, speed search from Minimum Speed	00	
0317H	50.24	5-35	Maximum Allowable Power Loss Time	0.3 to 5.0 sec	2.0	
0318H	50.25	5-35	Pause Time after Momentary Power Loss	0.3 to 10.0 sec	0.5	
0319H	50.26	5-36	Maximum Speed Search Current Level	30 to 200 %	150	
031AH	50.27	5-36	Upper Limit of Output Frequency	0.1 to 400.0 Hz	400.0	
031BH	50.28	5-36	Lower Limit of Output Frequency	0.0 to 400.0 Hz	0.0	
031CH	50.29	5-37	Skip Frequency 1	0.0 to 400.0 Hz	0.0	
031DH	50.30	5-37	Skip Frequency 2	0.0 to 400.0 Hz	0.0	
031EH	50.31	5-37	Skip Frequency 3	0.0 to 400.0 Hz	0.0	
031FH	50.32	5-37	Skip Frequency Bandwidth	0.1 to 20.0 Hz	0.0	
0320H	50.33	5-37	Auto Restart After Fault	00 to 10	00	
0321H	50.34	5-38	PID Set Point Location	00: Disable 01: Keypad (based on 20.03 setting) 02: AI1 (external 0-10V) 03: AI2 (external 4-20mA) 04: PID set point (50.43)	00	
0322H	50.35	5-38	Feedback Signal Selection	00: Positive AI1 (0-10V) 01: Negative AI1 (0-10V) 02: Positive AI2 (4-20mA) 03: Negative AI2 (4-20mA)	00	
0323H	50.36	5-38	P Gain Adjustment	0.0 to 10.0	1.0	
0324H	50.37	5-38	I Gain Adjustment	0.00 to 100.0 sec	1.00	
0325H	50.38	5-38	D Gain Adjustment	0.00 to 1.0 sec	0.00	
0326H	50.39	5-38	Upper Limit of Integral Control	00 to 100%	100	
0327H	50.40	5-38	PID Output Delay Filter Time	0.0 to 2.5 sec	0.0	
0328H	50.41	5-39	4-20mA Input Loss Detection Time	00: Disable 0.1 to 3600 sec	60	
0329H	50.42	5-39	4-20mA Input Loss Operation	00: Warn and Inverter Stop 01: Warn and Continue Operation	00	
032AH	50.43	5-39	PID Set Point	0.0 to 400.0 Hz (100.0%)	0.0	
032BH	50.44	5-39	PLC Operation Mode	00: Disable PLC performing 01: Execute one program cycle 02: Continuously execute program cycles 03: Execute one program cycle step by step 04: Continuously execute program cycles step by step	00	
032CH	50.45	5-42	PLC Forward/Reserve Motion	00 to 127	00	

Modbus	Groups	Page #	Description	Range	default	User settings
032DH	50.46	5-43	Time Duration of 1st Preset Speed	0 to 9999	0	
032EH	50.47	5-43	Time Duration of 2nd Preset Speed	0 to 9999	0	
032FH	50.48	5-43	Time Duration of 3rd Preset Speed	0 to 9999	0	
0330H	50.49	5-43	Time Duration of 4th Preset Speed	0 to 9999	0	
0331H	50.50	5-43	Time Duration of 5th Preset Speed	0 to 9999	0	
0332H	50.51	5-43	Time Duration of 6th Preset Speed	0 to 9999	0	
0333H	50.52	5-43	Time Duration of 7th Preset Speed	0 to 9999	0	
0334H	50.53	5-43	Auto Acceleration/Deceleration	00: Linear Acceleration/Deceleration	00	
				01: Auto Acceleration, Linear Deceleration		
				02: Linear Acceleration/Auto Deceleration		
				03: Auto Acceleration/Deceleration		
				04: Auto Acceleration/Deceleration Stall Prevention (Limited by 50.12 to 50.15)		
0335H	50.54	5-44	Sleep Frequency	0.0 Disabled 0.1 to 400Hz Enabled	0.0	
0336H	50.55	5-44	Wake Frequency	0.1 to 400Hz	0.0	
0337H	50.56	5-44	Sleep Time Delay	0.0 to 600 sec.	1.0	
0338H	50.57	5-44	Second Source of Master Frequency	00: Master Frequency determined by digital keypad up/down	00	
				01: Master Frequency determined by keypad potentiometer		
				02: Master Frequency determined by 0 to +10V input on AI terminal with jumpers		
				03: Master Frequency determined by 4 to 20mA input on AI terminal with jumpers		
				04: Master Frequency determined by RS-485 communication interface		

60 — MOTOR CONTROL

Modbus	Groups	Page #	Description	Range	default	User settings
0400H	60.01	5-45	Motor Rated Current	30 to 120 %	FLA	
0401H	60.02	5-45	Motor No-Load Current	00 to 99 %	0.4* FLA	
0402H	60.03	5-45	Motor Auto Tuning	00: Disable	00	
				01: DC test		
				02: DC test and no load test		
0403H	60.04	5-45	Motor's Stator Resistance (calculated via auto tune or entered manually)	00 to 65535 m Ohms	00	
0404H	60.05	5-46	DC Braking Current Level	00 to 100%	00	
0405H	60.06	5-46	DC Braking Time upon Start-up	0.0 to 5.0 sec	0.0	
0406H	60.07	5-46	DC Braking Time upon Stopping	0.0 to 25.0 sec	0.0	
0407H	60.08	5-47	Frequency-point for DC Braking	0.0 to 60.0Hz	0.0	
0408H	60.09	5-47	Torque Compensation	00 to 10	00	
0409H	60.10	5-48	Slip Compensation	0.00 to 10.00	0.0	
040AH	60.11	5-48	PWM Carrier Frequency	1 to 15 KHz	9	

70 — PROTECTIVE

Modbus	Groups	Page #	Description	Range	default	User settings
0500H	70.01	5-49	Over-voltage Stall Prevention	00: Disable 01: Enable	01	
0501H	70.02	5-49	Over Current Stall Prevention during Acceleration	00: Disable 20 to 200 %	150	
0502H	70.03	5-50	Over Current Stall Prevention during Operation	00: Disable 20 to 200 %	150	
0503H	70.04	5-50	Over-Torque Detection Mode (OL2)	00: Disabled 01: Enabled during constant speed operation, drive halted after fault 02: Enabled during constant speed operation, operation continues after fault 03: Enabled during operation, drive halted after fault 04: Enabled during operation, operation continues after fault	00	
0504H	70.05	5-51	Over-Torque Detection Level	30 to 200 %	150	
0505H	70.06	5-51	Over-Torque Detection Time	0.1 to 10.0 sec	0.1	
0506H	70.07	5-51	Electronic Thermal Overload Relay	00: Constant Torque 01: Variable Torque 02: Inactive	01	
0507H	70.08	5-52	Electronic Thermal Motor Overload Time	30 to 300 sec	60	
0508H	70.09	5-52	Auto Voltage Regulation (AVR)	00: AVR enabled 01: AVR disabled 02: AVR disabled during deceleration 03: AVR disabled during stop	00	
0509H	70.10	5-53	Auto Energy-Saving	00: Disable 01: Enable	00	
050AH	70.11	5-53	Under Current Detection Value	0.0 Disable 0.1 to No Load Amps	0.0	
050BH	70.12	5-53	Under Current Detection Mode	0 or 1	0	
050CH	70.13	5-53	Under Current Detection Time	0.0 to 20.0 sec.	1.0	

80 — KEYPAD/DISPLAY

Modbus	Groups	Page #	Description	Range	default	User settings
0600H	80.01	5-54	Software Version			
0601H	80.02	5-54	AC Drive Rated Current Display		###	
0602H	80.03	5-54	Manufacturer Model Information	00: MVXF50#0-2 (230V 1ph/3ph 0.5HP)	##	
				01: MVX001#0-2 (230V 1ph/3ph 1.0HP)		
				02: MVX002#0-2 (230V 1ph/3ph 2.0HP)		
				03: MVX003#0-2 (230V 1ph/3ph 3.0HP)		
				04: MVX005#0-2 (230V 3ph 5.0HP)		
				05: MVX007#0-2 (230V 3ph 7.5HP)		
				06: Reserved		
				07: Reserved		
				08: MVX001#0-4 (460V 3ph 1.0HP)		
				09: MVX002#0-4 (460V 3ph 2.0HP)		
				10: MVX003#0-4 (460V 3ph 3.0HP)		
				11: MVX005#0-4 (460V 3ph 5.0HP)		
				12: MVX007#0-4 (460V 3ph 7.5HP)		
				13: MVX010#0-4 (460V 3ph 10HP)		
0603H	80.04	5-55	Present Fault Record	00: No Fault occurred	00	
0604H	80.05	5-55	Second Most Recent Fault Record	01: Over-current (oc)	00	
0605H	80.06	5-55	Third Most Recent Fault Record	02: Over-voltage (ov)	00	
				03: Overheat (oH)		
				04: Overload (oL)		
				05: Overload 1 (oL1)		
				06: Overload 2 (oL2)		
				07: External Fault (EF)		
				08: CPU Failure 1 (CF1)		
				09: CPU Failure 2 (CF2)		
				10: CPU Failure 3 (CF3)		
				11: Hardware Protection Failure (HPF)		
				12: Over-current During Accel (OCA)		
				13: Over-current During Accel (OCd)		
				14: Over-current During Steady State (OCn)		
				15: Ground Fault or Fuse Failure (GFF)		
				16: Reserved		
				17: 3 Phase Input Power Loss		
				18: External Pause Function (bb)		
				19: Auto Adjust Accel/Decel Failure (cFA)		
20: Software Protection Code (codE)						

Modbus	Groups	Page #	Description	Range	default	User settings
0606H	80.07	5-55	Keypad Display selection (also order of appearance when scrolling through display modes)	00: Command Frequency ("F")	00	
				01: Output Frequency ("H")		
				02: Output Current ("A")		
				03: User Defined ("U")		
				04: Output Voltage (u)		
				05: Unit Temperature (t)		
				06: Forward/Reverse Direction ("Frd / rEv")		
				display only when enabled: Counter ("c")	xx	
				display only when enabled: PLC steps		
				display only when enabled: PID Feedback		
0607H	80.08	5-56	User Defined Multiplier	0.01 to 160.00	1.00	
0608H	80.09	5-56	External Terminal Scan Time	01 to 20	01	
0609H	80.10	5-56	Parameter Lock and Configuration	00: All parameters can be set and read	00	
				01: All parameters are read only		
				10: Reset all parameters to the factory defaults		
060AH	80.11	5-56	Elapsed Time (Run): Day	0 to 65535 (show 6553.)	0	
060BH	80.12	5-57	Elapsed Time (Run): Minutes	0 to 65535 (show 6553.)	0	
060CH	80.13	5-57	Elapsed Time (Power on): Day	0 to 65535 (show 6553.)	0	
060DH	80.14	5-57	Elapsed Time (Power on): Minutes	0 to 65535 (show 6553.)	0	
060EH	80.15	5-57	Automatic Display Scroll	00: Disable 01: Scroll every 5 seconds after 1 minute delay 02: Scroll every 15 seconds after 1 minute delay	00	

90 — COMMUNICATION PARAMETERS

Modbus	Groups	Page #	Description	Range	default	User settings
0700H	90.01	5-58	Communication Protocol	00: MODBUS ASCII mode < 7 data bits,no parity,2 stop bits >	00	
				01: MODBUS ASCII mode < 7 data bits,even parity,1 stop bit >		
				02: MODBUS ASCII mode < 7 data bits,odd parity,1 stop bit >		
				03: MODBUS RTU mode < 8 data bits,no parity,2 stop bits >		
				04: MODBUS RTU mode < 8 data bits,even parity,1 stop bit >		
05: MODBUS RTU mode < 8 data bits,odd parity,1 stop bit >						
0701H	90.02	5-58	RS-485 Communication	01 to d 254	01	
0702H	90.03	5-58	Transmission Speed	00: 4800 baud	01	
				01: 9600 baud		
				02: 19200 baud		
				03: 38400 baud		
0703H	90.04	5-59	Transmission Fault Treatment	00: Display fault and continue operating	03	
				01: Display fault and RAMP to stop		
				02: Display fault and COAST to stop		
				03: No fault displayed and continue operating		
0704H	90.05	5-59	Over time Detection	0.0: Disable	0.0	
				0.0~120.0 sec		

Appendix C – Accessories

Fuse Specification Chart

Smaller fuses than those shown in the table are permitted.

Model	Input Current (A)	Output Current (A)	Line Fuse	
			I (A)	Bussmann P/N
MVXF50A0-2 (1 phase)	6.3	2.5	25	JJN-25
MVXF50A0-2 (3 phase)	3.2	2.5	10	JJN-10
MVX001A0-2 (1 phase)	11.5	5	45	JJN-45
MVX001A0-2 (3 phase)	6.3	5	20	JJN-20
MVX002A0-2 (1 phase)	15.7	7	60	JJN-60
MVX002A0-2 (3 phase)	9	7	25	JJN-25
MVX003A0-2 (1 phase)	27	10	100	JJN-100
MVX003A0-2 (3 phase)	15	10	40	JJN-40
MVX005A0-2	19.6	17	60	JJN-60
MVX007A0-2	28	25	100	JJN-100
MVX001A0-4	4.2	3	10	JJS-10
MVX002A0-4	5.7	4	15	JJS-15
MVX003A0-4	6	5	20	JJS-20
MVX005A0-4	8.5	8.2	30	JJS-30
MVX007A0-4	14	13	50	JJS-50
MVX010A0-4	23	18	70	JJS-70

Recommended Fuses for UL approval

Equivalent fuse types = J class, CC class, T class and Type BS88 with a 600V limit.

Wiring Table

Catalog Number	Voltage, Horsepower	Max. Current(A) (Input/Output)	Wire Gauge (AWG)	Torque Rating (kgf-cm)
MVXF50A0-2 (1 phase)	240 VAC, 0.5 Hp	6.3	12-14	14
MVXF50A0-2 (3 phase)	240 VAC, 0.5 Hp	3.2	12-14	
MVX001A0-2 (1 phase)	240 VAC, 1 Hp	11.5	12-14	
MVX001A0-2 (3 phase)	240 VAC, 1 Hp	6.3	12-14	
MVX002A0-2 (1 phase)	240 VAC, 2 Hp	15.7	12	
MVX002A0-2 (3 phase)	240 VAC, 2 Hp	9	12-14	
MVX003A0-2 (1 phase)	240 VAC, 3 Hp	27	8	15
MVX003A0-2 (3 phase)	240 VAC, 3 Hp	15	8-12	
MVX005A0-2	240 VAC, 5 Hp	19.6	8-10	
MVX007A0-2	240 VAC, 7.5 Hp	28	8	
MVX001A0-4	480 VAC, 1 Hp	4.2	12-14	14
MVX002A0-4	480 VAC, 2 Hp	5.7	12-14	
MVX003A0-4	480 VAC, 3 Hp	6	12-14	
MVX005A0-4	480 VAC, 5 Hp	8.5	8-14	15
MVX007A0-4	480 VAC, 7.5 Hp	14	8-12	
MVX010A0-4	480 VAC, 10 Hp	23	8-10	

All Braking Resistors & Braking Units Used in AC Drives

Note: Please only use CUTLER-HAMMER recommended values. Other resistor values will void Cutler-Hammer's warranty. Please contact the nearest Cutler-Hammer representative near you for use of the special resistors. The resistors should be at least 10 cm away from AC drive to avoid possible noise.

Voltage	Applicable Motor		Full Load Torque kgf-m	Specification Resistors	Braking Resistors Model	No of Units Used	Braking Torque 10%ED%	Minimum Resistance rates
	HP	kW						
230 V Series	1/2	0.37	0.216	80W 200Ω	K13-000034-0821	1	220%	100Ω
	1	0.75	0.427	80W 200Ω	K13-000034-0821	1	125%	80Ω
	2	1.5	0.849	300W 70Ω	K13-000034-0824	1	125%	55Ω
	3	2.2	1.262	300W 70Ω	K13-000034-0824	1	125%	35Ω
	5	3.7	2.08	400W 40Ω	K13-000034-0825	1	125%	25Ω
	7.5	5.5	3.111	250W 60Ω	K13-000034-0826	1	125%	16Ω

460 V Series	1	0.75	0.427	80W 750Ω	K13-000034-0841	1	125%	260Ω
	2	1.5	0.849	300W 250Ω	K13-000034-0843	1	125%	190Ω
	3	2.2	1.262	300W 250Ω	K13-000034-0843	1	125%	145Ω
	5	3.7	2.08	400W 150Ω	K13-000034-0844	1	125%	95Ω
	7.5	5.5	3.111	250W 200Ω	K13-000034-0845	1	125%	60Ω
	10	7.5	4.148	350W 225Ω	K13-000034-0846	1	125%	45Ω

Note: Braking Torque 10% Estimated Duty%: braking torque at 10% duty cycle in (%).

EMI Filter Cross Reference

Model of AC Drive	hp/Voltage	EMI Filter
MVXF50A0-2	1/2 hp, 230Vac, Single phase	K13-000034-0111
MVX001A0-2	1 hp, 230Vac, Single phase	K13-000034-0111
MVX002A0-2	2 hp, 230Vac, Single phase	K13-000034-0111
MVX003A0-2	3 hp, 230Vac, Single phase	K13-000034-0112
MVXF50A0-2	1/2 hp, 230Vac, Three phase	K13-000034-0113
MVX001A0-2	1 hp, 230Vac, Three phase	K13-000034-0113
MVX002A0-2	2 hp, 230Vac, Three phase	K13-000034-0113
MVX003A0-2	3 hp, 230Vac, Three phase	K13-000034-0113
MVX001A0-4	1 hp, 460Vac, Single phase	K13-000034-0114
MVX002A0-4	2 hp, 460Vac, Single phase	K13-000034-0114
MVX003A0-4	3 hp, 460Vac, Single phase	K13-000034-0114
MVX005A0-2	5 hp, 230Vac, Three phase	K13-000034-0115
MVX007A0-2	7-1/2 hp, 230Vac, Three phase	K13-000034-0115
MVX005A0-4	5 hp, 460Vac, Three phase	K13-000034-0116
MVX007A0-4	7-1/2 hp, 460Vac, Three phase	K13-000034-0116
MVX010A0-4	10 hp, 460Vac, Three phase	K13-000034-0117

If users want to operate the AC motor drive in coordination with the EMI filters manufactured by CUTLER-HAMMER, refer to the above table for the appropriate I/O terminals of the applicable filters.



**The filter will cause a high leakage circuit.
Grounding is required.**

EMI Filters

EMI Filter (K13-000034-0111) Used on 0.5-2 HP/230V Single Phase Models.

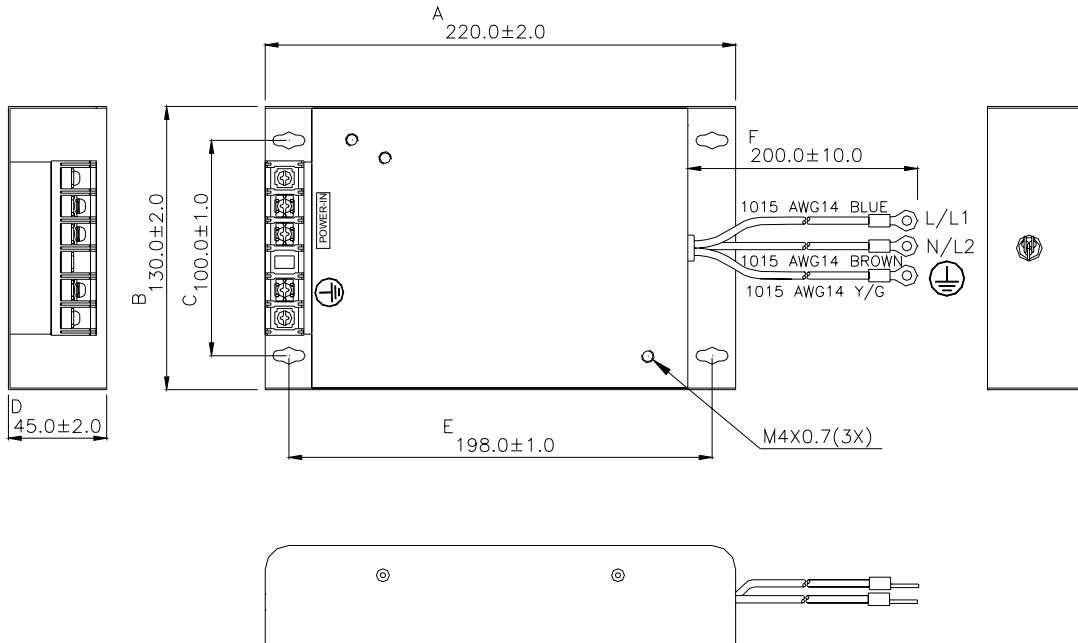

EMI Filter (K13-000034-0112) Used on 3 HP/230V Single Phase Models.

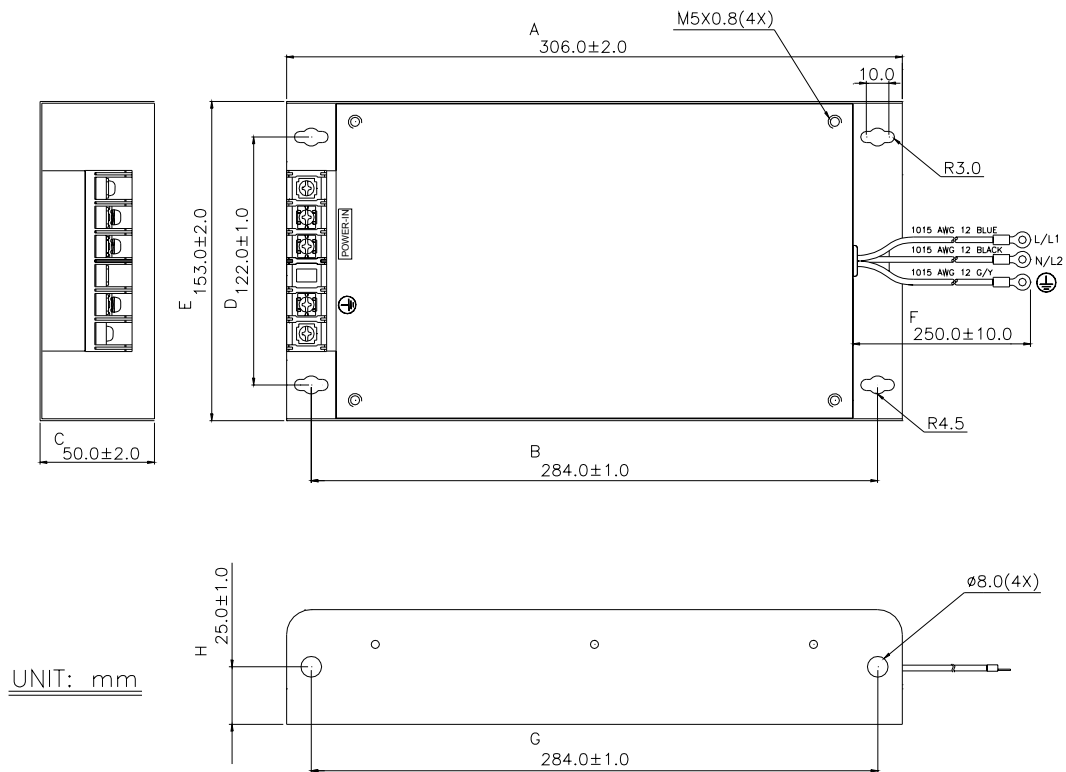

EMI Filter (K13-00034-0113) Used on 0.5-3 HP/230V Three Phase Models.

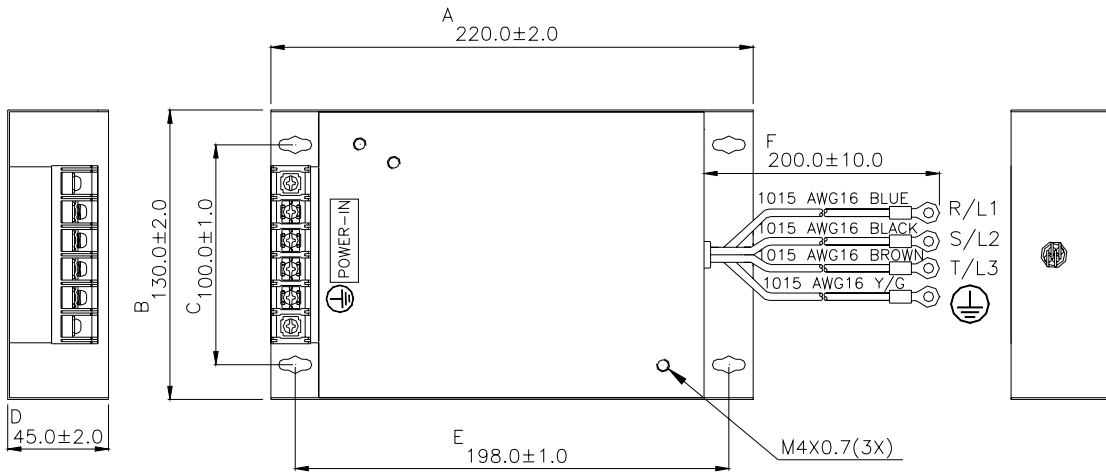

UNIT: mm

EMI Filter (K13-00034-0115) Used on 1-3 HP/460V Three Phase Models.

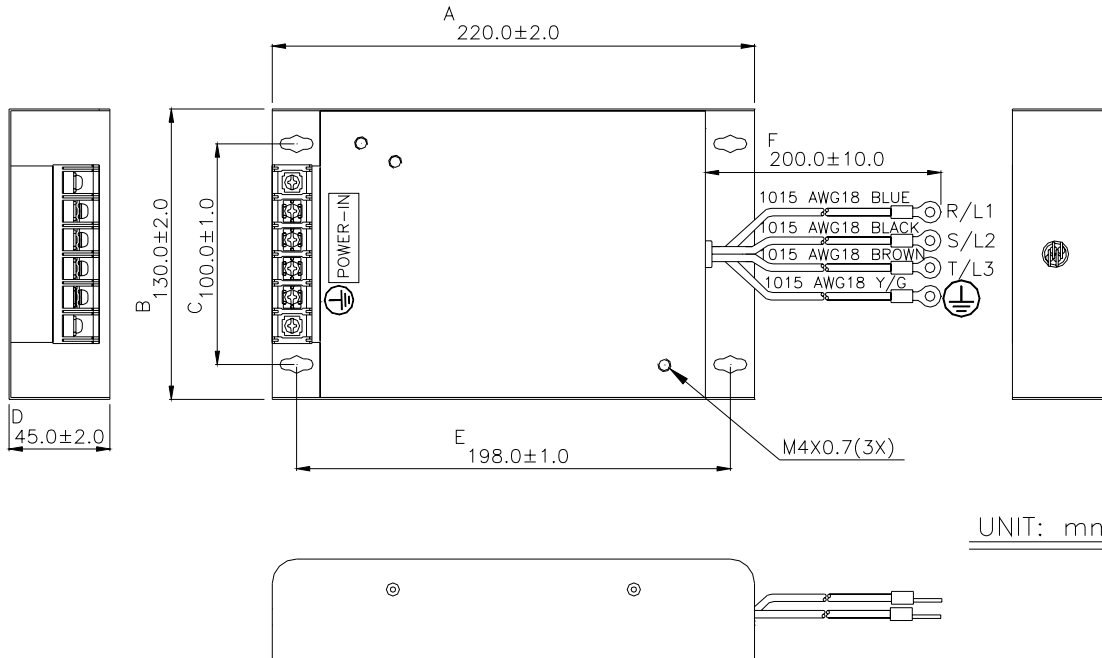

UNIT: mm

EMI Filter (K13-000034-0116) Used on 5-7.5 HP/230V Three Phase Models.

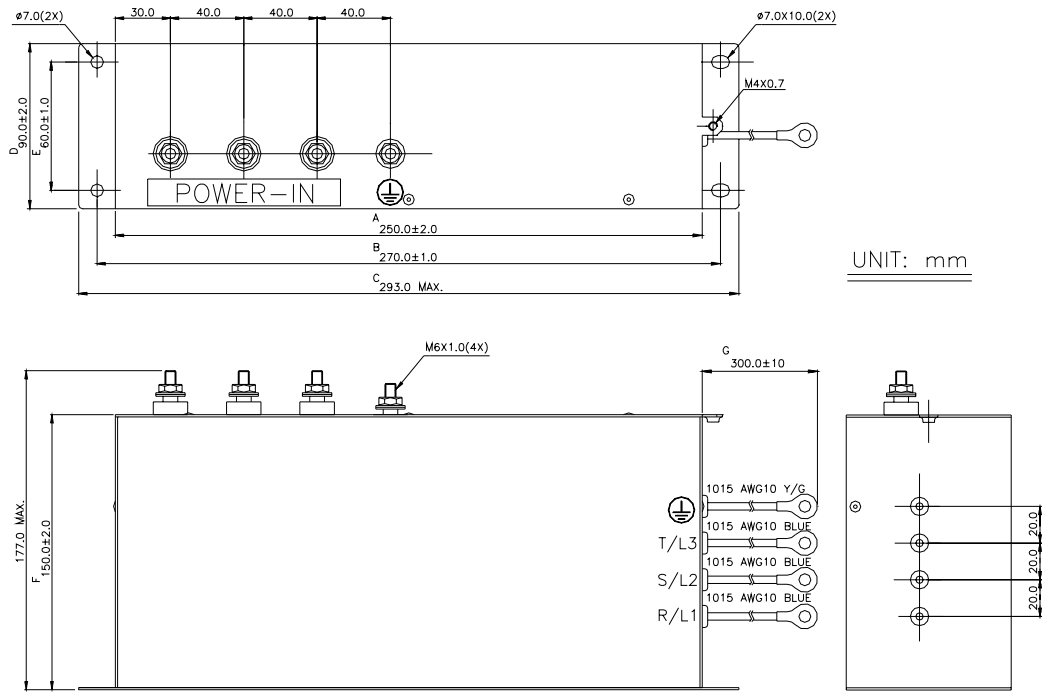

EMI Filter (K13-000034-0117) Used on 5-7.5 HP/460V Three Phase Models.

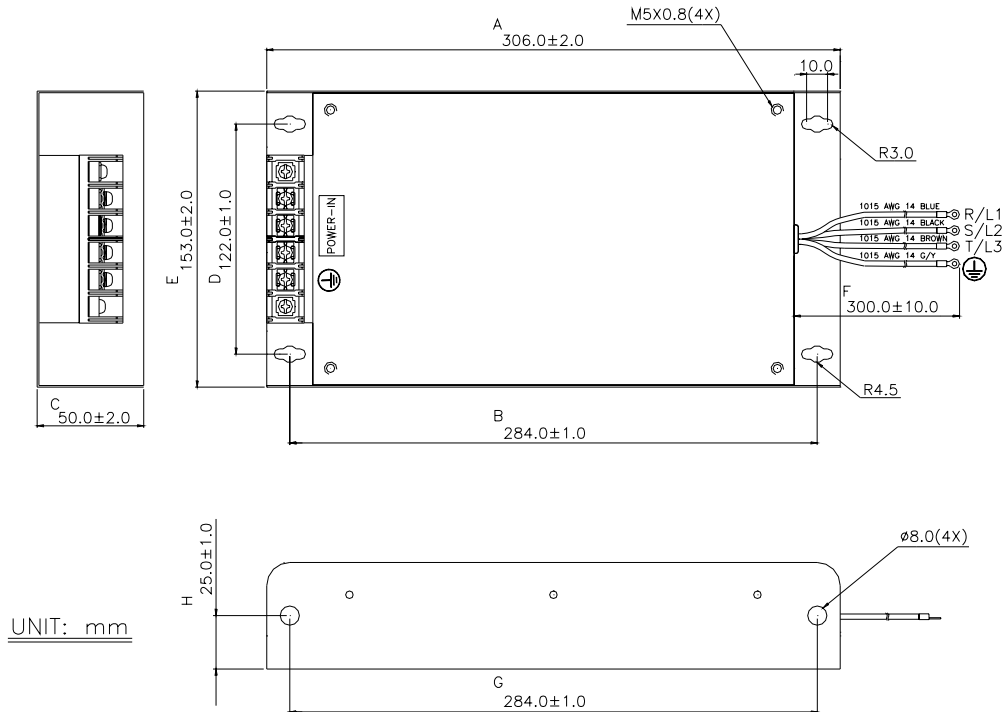

EMI Filter (K13-00034-0118) Used on 10 HP/460V Three Phase Models.

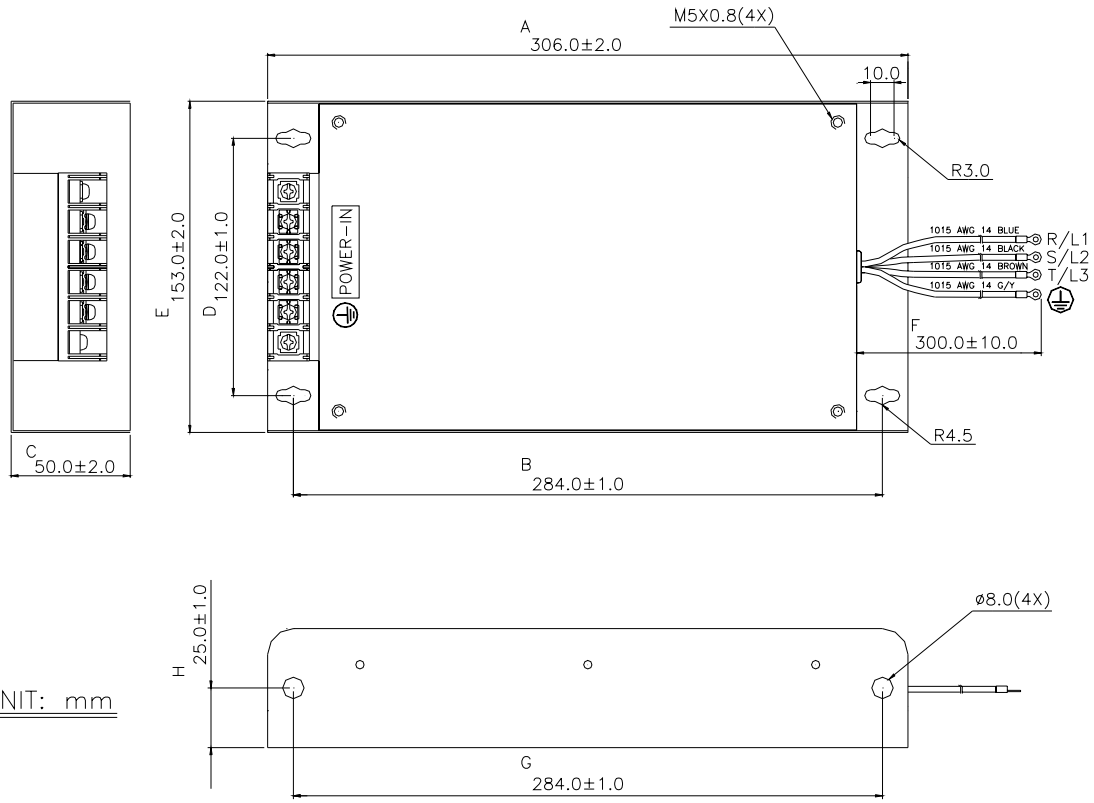

Din Rail Adapter (P/N: MVXDR)

Units: mm [inches]

To mount the drive on a Din Rail adapter, place the drive and mounting plate on the rail and push the lever toward the rail.

For Models: MVXF50A0-2, MVX001A0-2, MVX002A0-2, MVX001A0-4, MVX002A0-4, MVX003A0-4

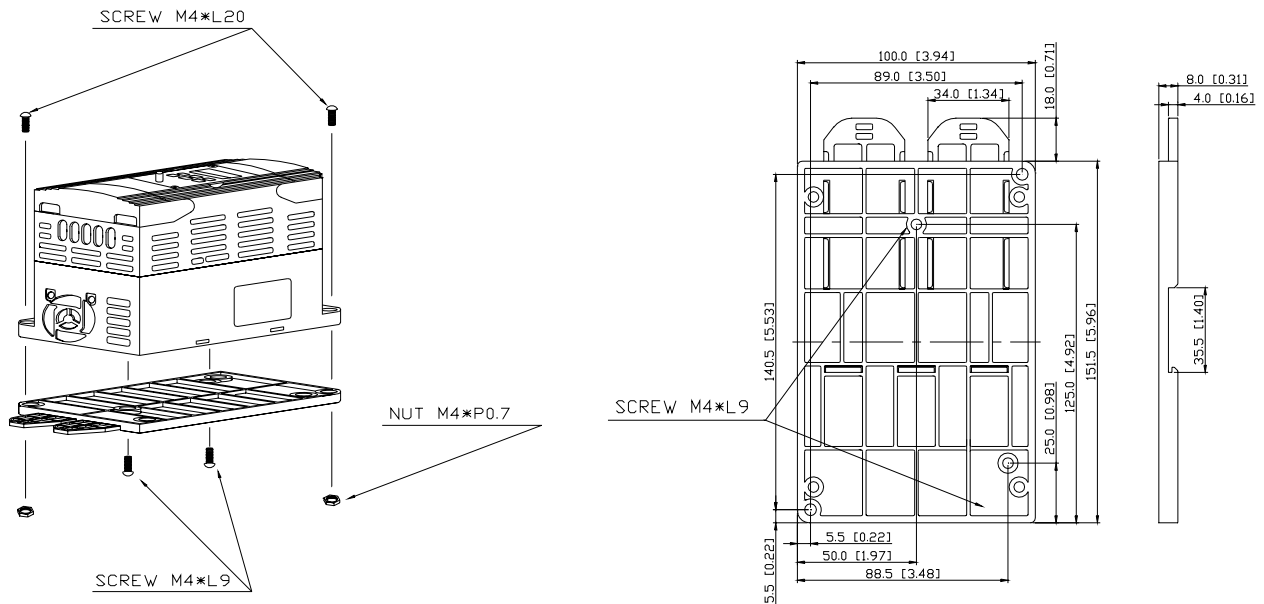

Remote Kit (P/N: MVXRM)

5 meter keypad cable

Unit: mm [ft' in"]

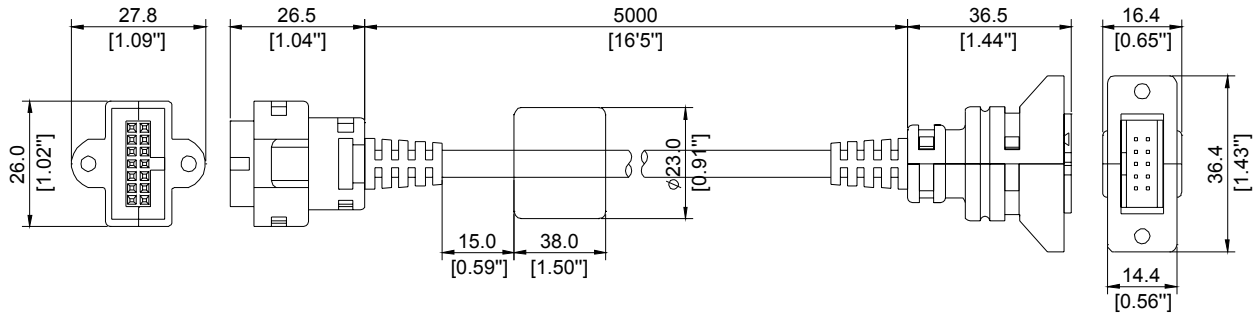

Extension Input/Output (P/N: MVXEIO)

Unit: mm [inches]

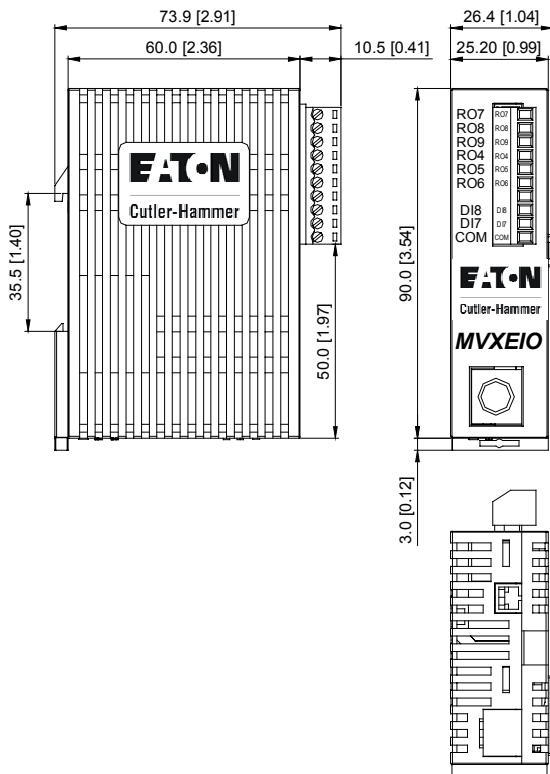

Terminal symbols	Terminal name	Remarks
R04-R05	Digital Output Relay	Refer to User Manual 40.04
R06-R05	Digital Output Relay	
R07-R08	Digital Output Relay	Refer to User Manual 40.04 Relay output contact R07-R08 (N.C. Contact) R09-R08 (N.O. Contact)
R09-R08	Digital Output Relay	
DI7 - COM	Digital input 7	Refer to User Manual 30.12
DI8 - COM	Digital input 8	

Appendix D – Dimensions

Digital Keypad

Unit: mm [inches]

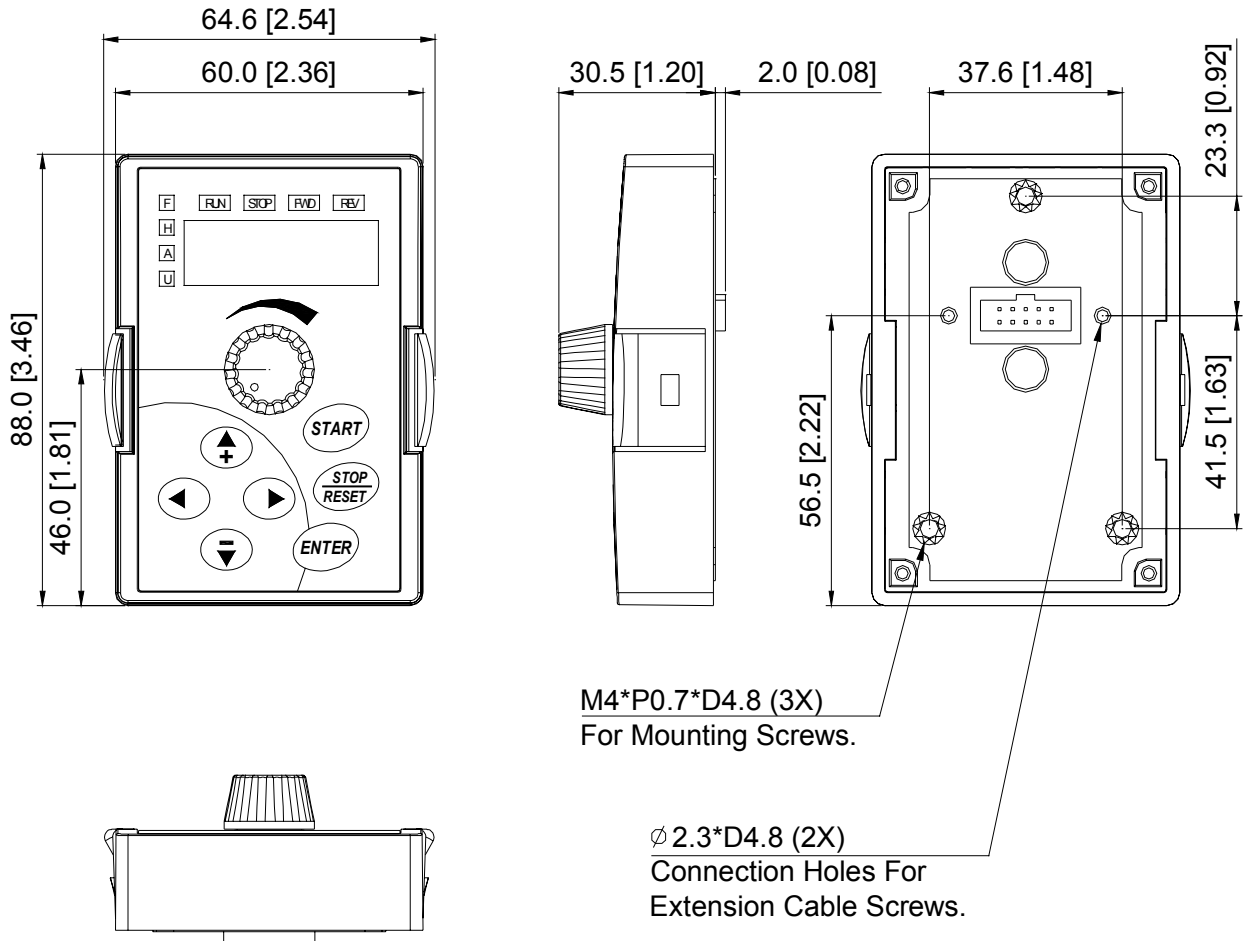

Digital Keypad – Mounting Panel A

Unit: mm [inches]

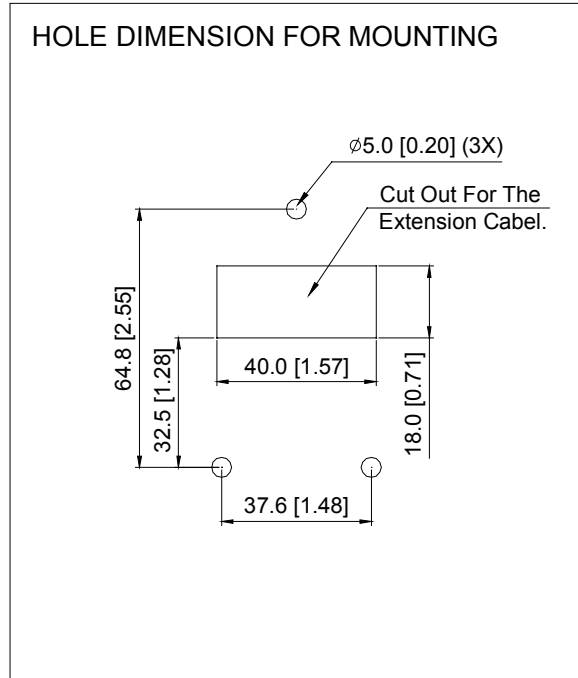
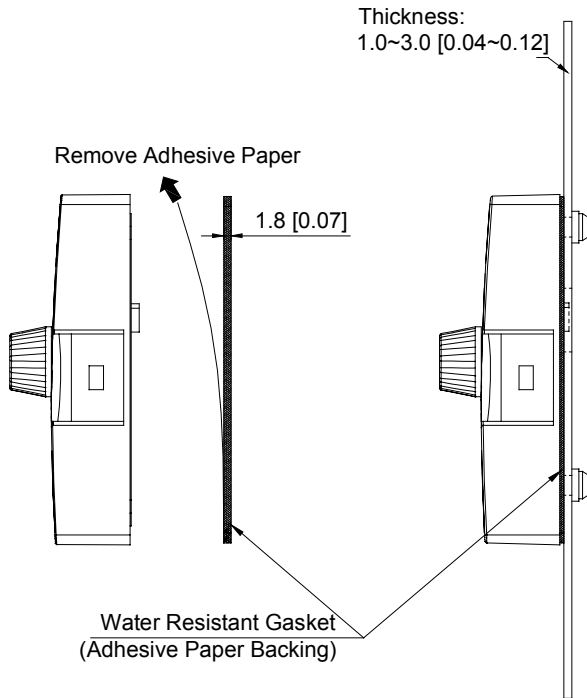

- MVXF50A0-2 (230V 1ph/3ph 0.5HP)
 - MX001A0-2 (230V 1ph/3ph 1.0HP)
 - MVX002A0-2 (230V 1ph/3ph 2.0HP)
 - MVX001A0-4 (460V 3ph 1.0HP)
 - MVX002A0-4 (460V 3ph 2.0HP)
 - MVX003A0-4 (460V 3ph 3.0HP)
- Unit: mm [inches]

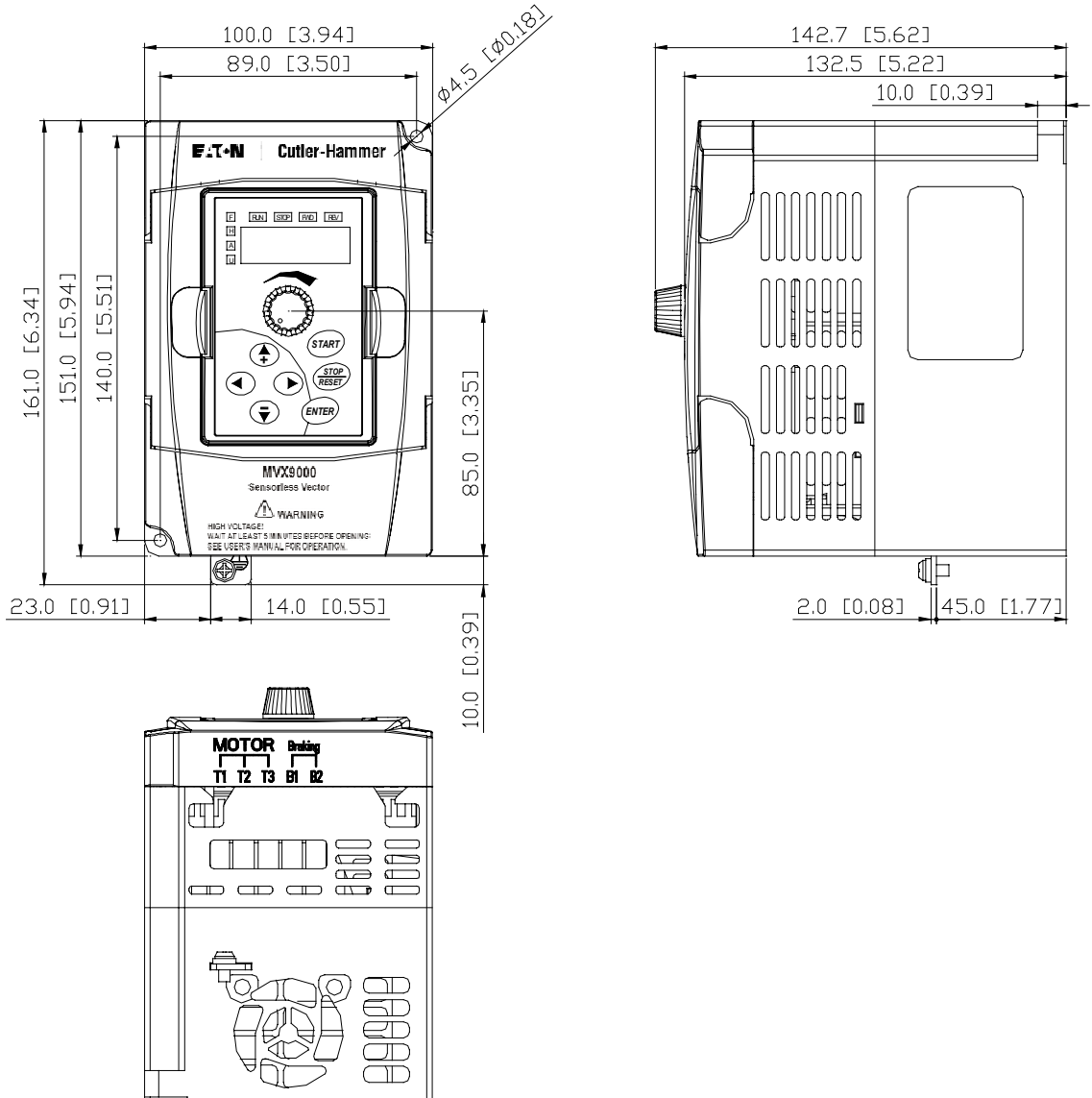

MVX003A0-2 (230V 1ph/3ph 3.0HP)

MVX005A0-2 (230V 3ph 5.0HP)

MVX007A0-2 (230V 3ph 7.5HP)

MVX005A0-4 (460V 3ph 5.0HP)

MVX007A0-4 (460V 3ph 7.5HP)

MVX010A0-4 (460V 3ph 10HP)

Unit: mm [inches]

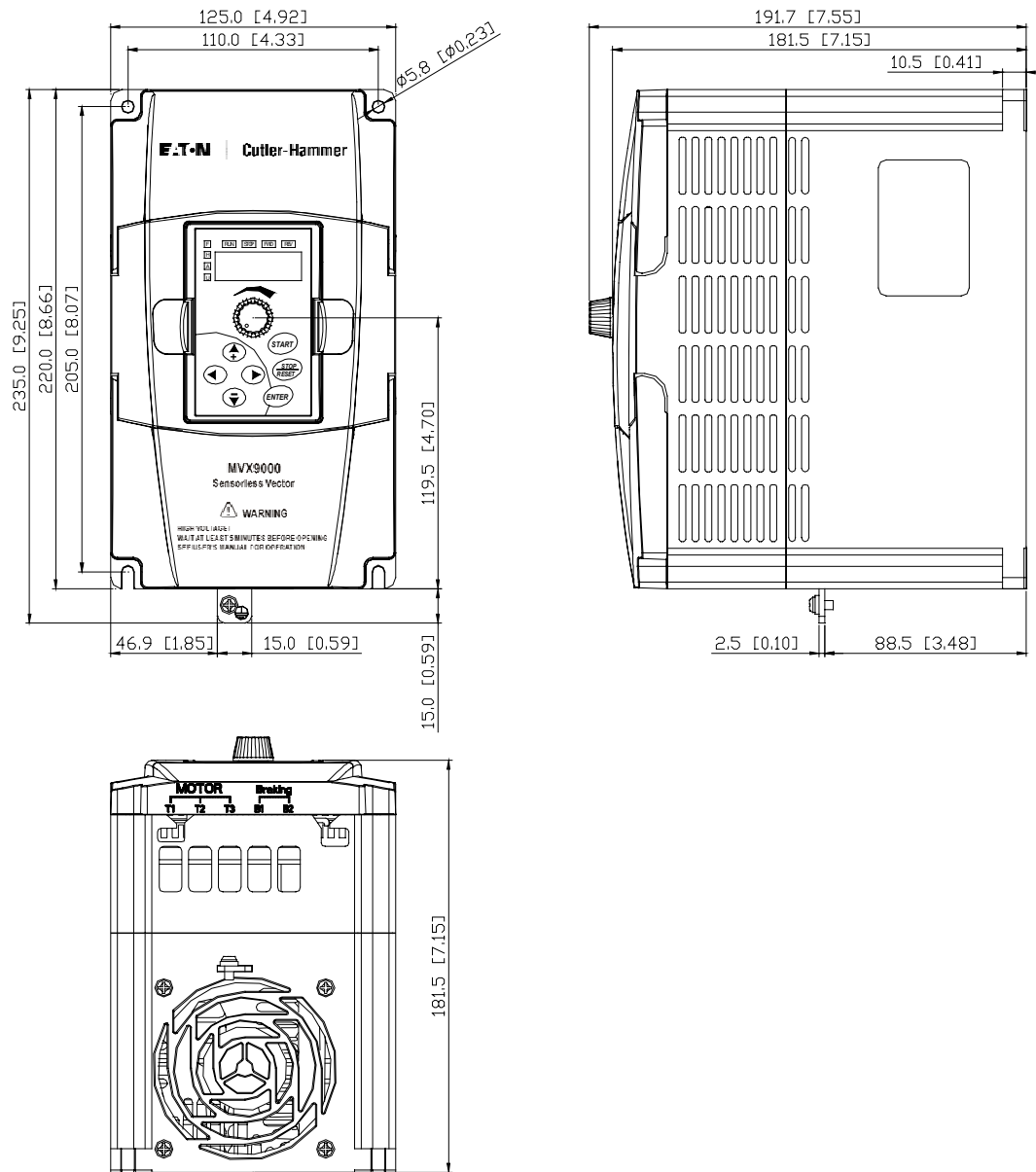

Appendix E – Declaration of Conformity

EC Declaration of Conformity

According to the Low Voltage Directive 73/23/EEC and the Amendment Directive 93/68/EEC Digital Keypad

For the following equipment:

AC Motor Drive
(Product Name)

MVXF50A0-2, MVX001A0-2, MVX002A0-2, MVX003A0-2, MVX005A0-2, MVX007A0-2,
MVX001A0-4, MVX002A0-4, MVX003A0-4, MVX005A0-4, MVX007A0-4, MVX010A0-4

(Model Name)

is herewith confirmed to comply with the requirements set out in the Council Directive 73/23/EEC for electrical equipment used within certain voltage limits and the Amendment Directive 93/68/EEC. For the evaluation of the compliance with this Directive, the following standard was applied:

EN 50178

The following manufacturer/importer is responsible for this declaration:

Eaton Cutler-Hammer
(Company Name)

31-1, Shien Pan Road, Kuei San Industrial Zone, Taoyuan Shien, Taiwan 333
(Company Address)

EC Declaration of Conformity

According to the Electromagnetic Compatibility 89/336/EEC and the Amendment Directive 93/68/EEC

For the following equipment:

AC Motor Drive
(Product Name)

**MVXF50A0-2, MVX001A0-2 , MVX002A0-2 , MVX003A0-2, MVX005A0-2 , MVX007A0-2,
MVX001A0-4, MVX002A0-4, MVX003A0-4, MVX005A0-4, MVX007A0-4, MVX010A0-4**

(Model Designation)

is herewith confirmed to comply with the requirements set out in the Council Directive 89/336/EEC for electromagnetic compatibility and the Amendment Directive 93/68/EEC. For the evaluation of the compliance with this Directive, the following standard was applied:

**EN61800-3, EN55011, EN50081-2, EN50082-2, EN61000-4-2, EN61000-4-3, EN61000-4-4,
EN61000-4-5, EN61000-4-6, EN61000-4-8**

The following manufacturer/importer is responsible for this declaration:

Eaton Cutler-Hammer
(Company Name)

31-1, Shien Pan Road, Kuei San Industrial Zone, Taoyuan Shien, Taiwan 333
(Company Address)

Cutler-Hammer, a part of Eaton Corporation, is a worldwide leader providing customer-driven solutions. From power distribution and electrical control products to industrial automation, Cutler-Hammer utilizes advanced product development, world-class manufacturing, and offers global engineering services and support.

For more information on Cutler-Hammer products, call 1-800-525-2000 or 1-616-982-1059, for engineering services call 1-800-498-2678, or visit our web site at www.cutler-hammer.eaton.com.

For Cutler-Hammer Adjustable Frequency Drives technical information and support, please call 1-800-322-4986.

Eaton Corporation
Cutler-Hammer business unit
1000 Cherrington Parkway
Moon Township, PA 15108-4312
USA
tel: 1-800-525-2000
www.cutler-hammer.eaton.com